



LTR-NET™ 8170 Series Portable Service Manual Addendum

8170 (800 MHz)
8172 (900 MHz)

7.5 VDC

1 & 3 W (800 MHz); 1 & 2.5 W (900 MHz)

Part No. 242-817x-x01

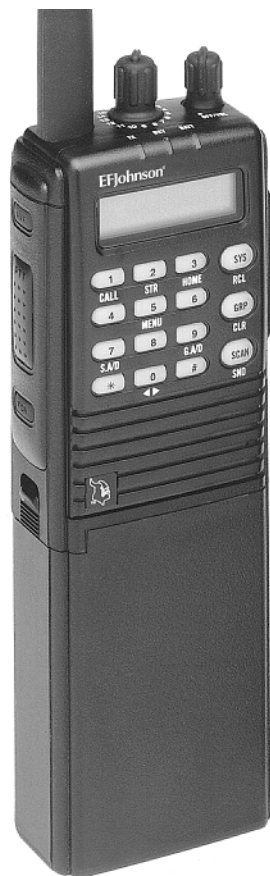

Keypad Model



Standard Model

First Printing
April 1999



817x SERIES LTR-NET™ PORTABLE FM TWO-WAY RADIO

SERVICE MANUAL ADDENDUM

**8170 (800 MHz) 1 & 3 Watts
8172 (900 MHz) 1 & 2.5 Watts
7.5 VDC, Part No. 242-817x-x0x**

Copyright© 1999 by Transcript International Incorporated

Transcript offers communication solutions in two core areas: land mobile radio products and systems, and information security. EFJohnson land mobile radios and systems provide wireless communication for a variety of markets including government, public safety, and commercial users. Transcript's information security devices utilize sophisticated scrambling and encryption techniques to protect sensitive voice and data transmissions.

Viking Head/EFJohnson logo, LTR-Net™, LTR®, and Call Guard® are trademarks of Transcript International Incorporated. All other company and/or product names used in this manual are trademarks and/or registered trademarks of their respective manufacturer.

Information in this manual is subject to change without notice.

NOTES

TABLE OF CONTENTS

1	GENERAL INFORMATION	
1.1	SCOPE OF ADDENDUM	1-1
1.2	DIFFERENCE BETWEEN LTR AND LTR-NET VERSIONS	1-1
1.3	TRANSCEIVER IDENTIFICATION	1-1
1.4	PART NUMBER BREAKDOWN	1-1
1.5	ACCESSORIES	1-1
1.6	LTR-NET TRANSCEIVERS	1-2
2	OPERATION	
2.1	OPERATING FEATURES	2-1
	Features Standard With Both Versions	2-1
	Additional Features Available With Keypad	
	Model	2-1
	LTR-Net And LTR Features	2-2
	Conventional Features	2-2
2.2	TRANSCEIVER CONTROLS	2-2
	Top Panel Controls	2-2
	Top Panel Indicators	2-2
	Side Controls	2-2
	Front Panel Keys (Without Telephone Keypad)	2-3
	Front Panel Keys (With Telephone Keypad)	2-3
	Display Information	2-4
2.3	GENERAL OPERATION	2-4
	Backlight Operation	2-4
	System/Group Display Mode	2-4
	System And Group Select	2-5
	Squelch Adjust	2-5
	LTR-Net, LTR, And Conventional Operating	
	Modes	2-5
	Localities, Systems, And Groups	2-6
	Placing And Receiving Standard Group Calls	2-7
2.4	GENERAL FEATURES	2-8
	Auxiliary Switch	2-8
	Call Indicator	2-8
	Companding	2-8
	Emergency Calls	2-8
	Home Key	2-8
	Keypad Lock	2-8
	Key Press Tone	2-9
	Low Battery Indicator	2-9
	Power Select	2-9
	Time-Out Timer	2-9
2.5	QUICK SELECT SWITCH	2-9
	Standard Model	2-9
	Telephone Keypad Models	2-10
	Operation With A Locked Position Selected	
	(All Models)	2-10
2.6	MENU MODE	2-10
2.7	PHONE MODE	2-11
	General	2-11
	Selecting And Exiting The Phone Mode	2-12
	Entering The Telephone Number	2-12
	Storing And Recalling Numbers	2-12
	Terminating A Call	2-13
2.8	SYSTEM AND GROUP SCAN	2-13
	System Scanning	2-13
	Group Scanning	2-13
	General Scanning Information	2-14
	Scan Operation In Various Modes	2-14
	Scan List Programming	2-15
	Scan Delay Timers	2-15
	Transmitting While Scanning	2-16
2.9	LTR-NET AND LTR FEATURES	2-16
	Receive Priority ID Codes	2-16
	Block ID Codes and Access Priority	2-17
	Standard Group Calls	2-17
	Proceed (Clear-To-Talk) Tone	2-17
	Transmit Inhibit	2-18
2.10	LTR-NET FEATURES	2-18
	Special Calls	2-18
	Busy Queuing/Free System Ringback	2-20
	Roaming (Auto-Registration)	2-20
	Over-The-Air Locality Channel Updates	2-21
	Transceiver Disable	2-21
	Home Channel Aliasing	2-22
2.11	LTR FEATURES	2-22
	General LTR Features	2-22
	LTR Telephone Calls	2-23
	Free System Ringback, System Search, and	
	Transpond	2-24
2.12	CONVENTIONAL FEATURES	2-24
	Monitor Mode	2-24
	Transmit Disable On Busy	2-24
	Receive-Only Groups	2-24
	Talk-Around Groups	2-24
	Call Guard Squelch	2-24
	Priority Group Sampling	2-25
2.13	SUPERVISORY TONES	2-25
	General Tones	2-25
	LTR-Net Special Call Tones	2-26
	LTR Telephone Call Tones	2-26
2.14	DISPLAY MESSAGES	2-26
2.15	TEST MODE	2-27

TABLE OF CONTENTS (CONT'D)

3 TRANSCIVER PROGRAMMING

3.1 GENERAL 3-1
 Programming Setup 3-1
 Computer Description 3-1
 Remote Programming Interface (RPI) 3-1
 EEPROM Data Storage 3-2
 Software Description 3-2
 Software Installation 3-2
 Connecting Programming Setup 3-2
 Starting Program 3-3
 Operation With LCD Screens 3-3

3.2 MAIN MENU PARAMETERS 3-3
 Introduction 3-3
 SELECT Menu 3-3
 EDIT Menu 3-3
 RADIO INTERFACE Menu 3-5
 SYSTEM Menu 3-5
 FILES Menu 3-6
 SETUP Menu 3-6

3.3 MISCELLANEOUS INFORMATION 3-6
 Repeater Number Programming 3-6
 Channel Number Programming 3-7
 Specifying RIC-Equipped Repeaters
 (LTR Only) 3-7

3.4 PROGRAMMING ERRORS 3-7

3.5 CLONING 3-7

4 LTR-NET™ OVERVIEW

4.1 INTRODUCTION 4-1
 General 4-1
 Compatibility With LTR 4-1
 LTR-Net Features 4-2
 Definitions 4-3

4.2 SYSTEM ARCHITECTURE 4-3
 Introduction 4-3
 Subscriber Units 4-3
 Repeaters 4-4
 3000-Series Switch 4-4
 Call Processor 4-5
 System and Subscriber Manager 4-5

4.3 STANDARD GROUP CALLS 4-5

4.4 WIDE AREA GROUP CALLS 4-5

4.5 SPECIAL CALLS 4-6
 General 4-6
 Auxiliary Calls 4-6
 Telephone Calls 4-6
 Data Calls 4-6

4.6 HOME CHANNEL BACKUP 4-6
 Introduction 4-6
 Home Repeaters 4-7
 Status Repeaters 4-7
 Backup Operation 4-7
 Home Channel Aliasing 4-7

4.7 OTHER LTR-NET FEATURES 4-7
 Unique ID Codes 4-7
 Electronic Serial Number (ESN) 4-8
 ESN and Unique ID Requests 4-8
 Interrogate 4-8
 Kill and Sleep 4-8
 Over-The-Air Reprogramming 4-8
 Move to Specific System/Group 4-8
 Auto-Registration and De-Registration 4-8
 New Channel Updates 4-9

LIST OF FIGURES

2-1 Standard Model (Without Keypad) 2-1
 2-2 Telephone Keypad Model 2-1
 2-3 Top Panel Controls 2-2
 3-1 Programming Setup 3-1
 3-2 Main Menu Bar 3-3
 4-1 LTR-Net System 4-1

LIST OF TABLES

1-1 8170 Accessories 1-1
 1-2 EFJohnson LTR-Net Transceivers 1-2
 2-1 800 MHz Default Test Channels 2-28
 2-2 900 MHz Default Test Channels 2-28
 3-1 Radio Parameters Screen 3-8
 3-2 LTR-Net System Parameters 3-9
 3-3 LTR System Screen Description 3-11
 3-4 Conventional System Parameter Description 3-13
 3-5 Call Guard Codes and Tones 3-14

SECTION 1 GENERAL INFORMATION

1.1 SCOPE OF ADDENDUM

This addendum updates the current Avenger® SI service manual with information for the new LTR-Net 8170 transceiver. The service manual it updates is as follows:

Title: Avenger SI 8150-Series LTR Service Manual
Part Number: 001-8150-002
Printing Date: May 1996

1.2 DIFFERENCE BETWEEN LTR AND LTR-NET VERSIONS

The difference between the LTR 8150 series and LTR-Net 8170 series transceivers is the software in microcomputer IC306. The part number of IC306 with LTR-Net software is as follows:

IC306 w/LTR-Net Software - P.N. 023-9998-461

All electrical and mechanical components remain the same. Therefore, this addendum contains only operation and programming information. Use the current sections of your service manual for all other servicing information.

Different software is also used to program the LTR and LTR-Net versions of this transceiver. Both programs are similar DOS programs. However, the LTR program cannot be used to program an LTR-Net transceiver and vice versa. The part number of the LTR-Net software is shown in Table 1-1.

1.3 TRANSCEIVER IDENTIFICATION

The transceiver identification number is printed on a label that is affixed to the back cover. The following information is contained in that number:

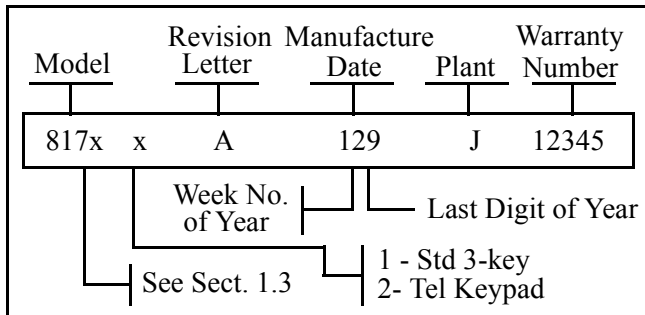

1.4 PART NUMBER BREAKDOWN

The following is a breakdown of the number used to identify the various versions of this transceiver:

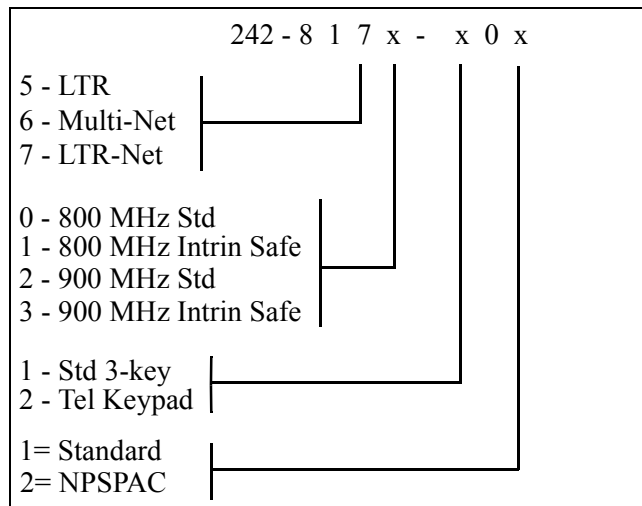

1.5 ACCESSORIES

Table 1-1 is a partial listing of accessories that are available for the 8170 transceiver. Refer to this table in the Avenger SI service manual for other accessories that are available.

Table 1-1 8170 Accessories

Accessory	Part No.
Speaker-microphone, amplified	589-0015-040
Earphone Adapter	585-5000-051
Earphone, standard (for -040/-051)	589-9003-004
Earphone, Intrin Safe (for -040/-051)	250-0881-004
Programming Accessories	
Remote Prog Interface (RPI)	023-9800-000
Programming cable (RPI to xcvr)	597-2002-122
DB9 F to DB9 M 6-ft cable	597-5900-002
DB25 M to DB25 M 6-ft cable	023-5800-016
DB25 M to DB25 F 6-ft cable	023-5800-017
DB-25 M to DB-9 F 6-ft cable	597-0005-057
Prog. software, 3½" diskette for LTR-Net 817x models only	023-9998-462

1.6 LTR-NET TRANSCEIVERS

EFJohnson LTR-Net transceivers are listed in Table 1-2.

Table 1-2 EFJohnson LTR-Net Transceivers

Model	Freq (MHz)	Localities [1]	Systems [1]	Groups [1]	Type	Power Output	Other Features
8170	800	14	14	10	Portable	3.0/1.0W	Small size, qk sel sw, user sel pwr output
8171	800	14	14	10	Portable	2.0/1.0W	Small size, qk sel sw, sel pwr, Intrin Safe
8172	900	14	14	10	Portable	2.5/1.0W	Small size, qk sel sw, user sel pwr output
8173	900	14	14	10	Portable	2.0/1.0W	Small size, qk sel sw, sel pwr, Intrin Safe
9843	400	35	99	99	Mob Dash	25 or 40W	High-tier, up to 16 banks selectable
9883	800	35	99	99	Mob Dash	15 or 30W	High-tier, up to 16 banks selectable
9896	900	35	99	99	Mob Dash	15 or 30W	High-tier, up to 16 banks selectable

[1] With 9800-series high tier transceivers, up to approximately 35 LTR-Net or 60 conventional localities are programmable. Due to memory limitations, the maximum number decreases as the total number of localities, systems, and groups increases.

SECTION 2 OPERATION

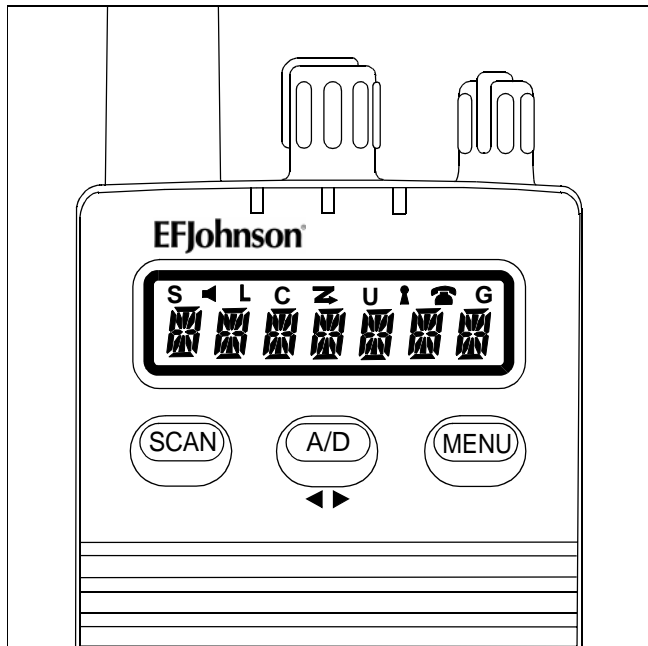

Figure 2-1 Standard Model (Without Keypad)

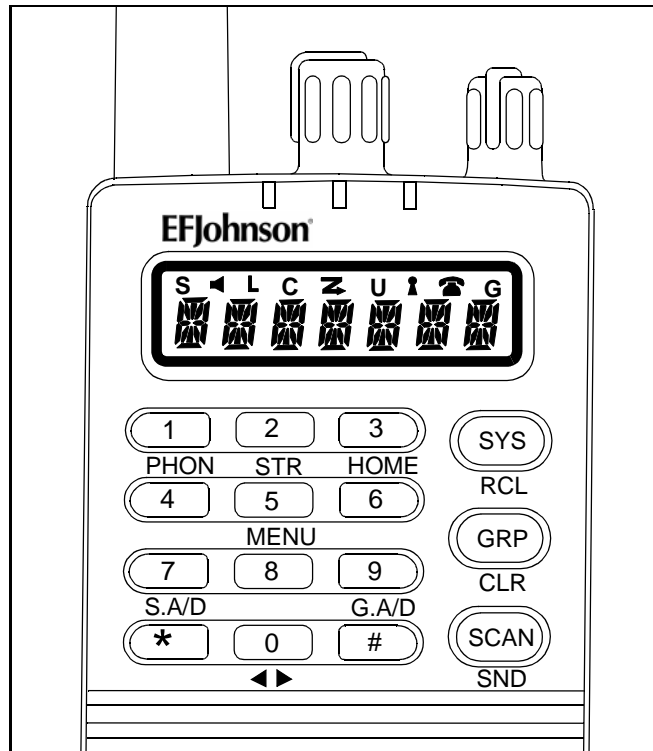

Figure 2-2 Telephone Keypad Model

2.1 OPERATING FEATURES

2.1.1 FEATURES STANDARD WITH BOTH VERSIONS

There are standard and telephone keypad versions of this transceiver available (see Figures 2-1 and 2.1). The following features are available with both models.

- Up to 14 LTR-Net™, LTR®, and conventional systems/localities programmable
- Up to 10 groups programmable per system
- Up to 16 system/group combinations selectable by top panel quick select switch
- LCD display which indicates selected system/group, operating modes, error conditions, and other information
- System scan (LTR and conventional systems only)
- User selectable high and low power output

- Menu mode to select various features
- Call indicator
- Time-out timer
- Low-battery indicator
- Numeric or alpha system/group display modes
- Test mode

2.1.2 ADDITIONAL FEATURES AVAILABLE WITH KEYPAD MODEL

- Up to 14 systems and 10 groups selectable by front panel SYS and GRP keys
- Keypad for dialing telephone numbers and selecting additional features
- Phone mode for convenient dialing of telephone and other numbers
- Memory to store up to 6 telephone numbers (each can be up to 14 digits in length)
- User programmable quick select switch

2.1.3 LTR-NET AND LTR FEATURES

Additional features that are available when the selected system is programmed for LTR-Net or LTR operation are as follows:

- Group scan
- User programmable group scan list (telephone keypad models only)
- Proceed (clear-to-talk) tone
- Transmit inhibit
- Roaming (LTR-Net only)
- Special calls (LTR-Net only)

NOTE: LTR free system ringback, system search, and transpond are not available with this transceiver.

2.1.4 CONVENTIONAL FEATURES

The following additional features are available when the selected system is programmed for conventional operation.

- Each group selects a specific radio channel
- Tone or digital Call Guard squelch or standard carrier squelch programmable on each group
- Busy indicator
- Receive-only channels
- Repeater talk-around
- Transmit Disable On Busy

NOTE: Group scan and priority sampling are not available on conventional systems.

2.2 TRANSCEIVER CONTROLS

2.2.1 TOP PANEL CONTROLS

On-Off/Volume - Turning this knob clockwise turns power on and sets the volume level. Turning it counterclockwise to the detent turns power off. Power is on when information appears in the display. If the key press tone is enabled, any key can be pressed to provide a reference tone for setting the volume level. Otherwise, the volume level is determined by noting the position of the index on the knob.

Quick Select Switch - Selects up to 16 system/group combinations. Refer to Section 2.5 for more information.

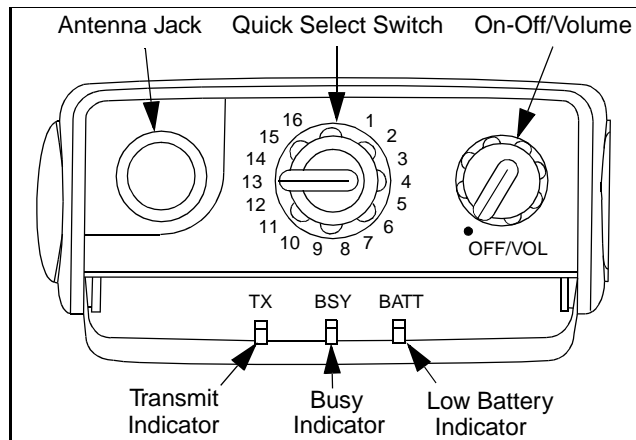

Figure 2-3 Top Panel Controls

Antenna Jack - Connection point for the antenna.

2.2.2 TOP PANEL INDICATORS

Transmit Indicator (Red) - Lights when the transmitter is keyed.

Busy Indicator (Green) - Lights when a carrier is detected on a conventional group (channel).

Low-Battery Indicator (Amber) - Lights when a low-battery condition is detected (see Section 2.4.8).

2.2.3 SIDE CONTROLS

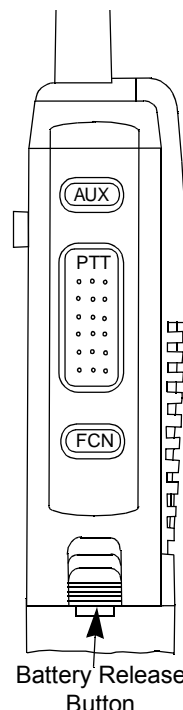

AUX (Auxiliary) - Toggles the conventional monitor mode on and off and momentarily disables scanning. Pressing this switch twice turns group scanning on and off (see Section 2.4.1).

Push-To-Talk Switch - Pressing this switch keys the transmitter. The red indicator on the top panel lights when the transmitter is keyed.

FCN - This switch enables the alternate function of the front panel keys for 3 seconds. Turning power on with this switch pressed enables all icons in the display and displays "PROG CH". Pressing FCN * displays the software version number (keypad models only).

Accessory Connector - Connection point for the RPI when programming the transceiver and also for optional speaker-microphones. This connector is located on the side opposite the PTT switch.

Battery Release Button - Pushing this spring-loaded button upward releases the battery so that it can be slid sideways and removed for recharging or replacement.

NOTE: Be sure to turn power off before removing the battery. If you do not, current settings may not be saved in memory.

2.2.4 FRONT PANEL KEYS (MODELS WITHOUT TELEPHONE KEYPAD)

The standard model front panel controls are shown in Figure 2-1 on page 2-1. The FCN switch on the side must first be pressed to enable the main function of these keys. They operate as follows:

SCAN - Pressing the FCN switch on the side and then this switch turns the system scan feature on and off. System scanning is enabled when **Z** is displayed (see Section 2.8).

A/D (◀▶) - Pressing the FCN switch on the side and then this switch changes the scan list status of the system currently selected by the quick select switch (see Section 2.5.1). Pressing this key without first pressing FCN toggles the system/group display mode (either numeric or alpha tag). Refer to Section 2.3.2 for more information.

MENU - Pressing the FCN switch on the side and then this key selects the menu mode which is used to select power output, keypad lock, key tone disable, and proceed tone disable and loudness (see Section 2.6).

2.2.5 FRONT PANEL KEYS (MODELS WITH TELEPHONE KEYPAD)

The telephone keypad model front panel controls are shown in Figure 2-2 on page 2-1. The alternate function of these keys is enabled by pressing the FCN switch on the side.

SYS (RCL) - Increases the selected system number. Pressing FCN and then this key decreases the system

number. In the phone mode, pressing this key and then a number from 1-6 recalls the number stored in that memory location (see Section 2.7).

GRP (CLR) - Increases the selected group number. Pressing FCN and then this key decreases the group number. In the phone mode, this key clears the last number in the display (see Section 2.7).

SCAN (SND) - Turns the system scan feature on and off. System scanning is enabled when **Z** is displayed (see Section 2.8). Pressing FCN and then this key selects the phone mode and the preprogrammed telephone system/group. In the phone mode, pressing this key with the dial tone sounding sends the number in the display (see Section 2.7).

1 (PHON) - Dials a “1” when entering a telephone number. Pressing FCN and then this key selects the phone mode without changing the displayed system/group (see Section 2.7).

2 (STR) - Dials a “2” when entering a telephone number. Pressing FCN and then this key programs the current quick select switch position with the selected system/group (see Section 2.5). When the phone mode is selected, pressing FCN, this key, and then a number from 1-6 stores the current number in that memory location (see Section 2.7).

3 (HOME) - Dials a “3” when entering a telephone number. Pressing FCN and then this key selects either the home or last active system/group (see Section 2.4.5).

4 - Dials a “4” when entering a telephone number.

5 (MENU) - Dials a “5” when entering a telephone number. Pressing FCN and then this key selects the menu mode (see Section 2.6).

6 - Dials a “6” when entering a telephone number.

7 (S. A/D) - Dials a “7” when entering a telephone number. Pressing FCN and then this key changes the scan list status of the displayed system. The system is in the scan list and scanned normally if “S” is displayed when not scanning (see Section 2.8.5).

8 - Dials an “8” when entering a telephone number.

9 (G. A/D) - Dials a “9” when entering a telephone number. With LTR-Net and LTR systems that are programmed for group scan, pressing FCN and then this key changes the scan list status of the displayed group. The group is in the scan list and scanned normally if “G” is displayed when not system scanning (see Section 2.8.5).

0 (◀▶) - Dials a “0” when entering a telephone number. When not in the phone mode, pressing FCN and then this key toggles the display between the numeric and alpha tag modes (see Section 2.3.2). When in the phone mode, pressing RCL and then this momentarily displays the digits that have scrolled out of the display. In the menu mode, pressing this key steps through the various parameters.

***** - Enters the DTMF “*” character when dialing a telephone number. Pressing FCN * displays the software version number.

- Enters the DTMF “#” character when dialing a telephone number. When in the phone mode and making an LTR-Net or LTR telephone call, pressing this key terminates the call (* # may also be used).

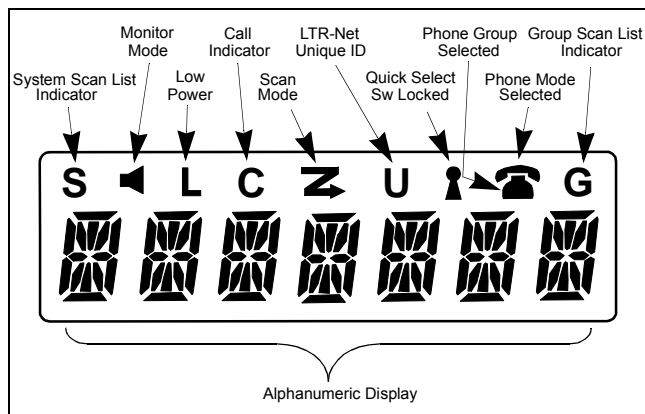

2.2.6 DISPLAY INFORMATION

Alphanumeric Display - This seven-character display indicates either the system/group number or alpha tag, depending on display mode selected (see Section 2.3.2). It also indicates operating modes and error conditions. In phone mode (telephone keypad models), the telephone number is displayed in this area.

S - Indicates that the displayed system is in the scan list and scanned normally. When scanning is occurring, this indicator is not displayed.

G - Indicates that the displayed group is in the scan list and scanned normally (LTR-Net and LTR systems only). When scanning is enabled, this indicator is not displayed.

◀ - Indicates that the conventional monitor mode has been enabled by the AUX switch on the side (see Section 2.12.1).

L - Indicates that the low-power mode is selected manually by the menu mode (see Section 2.6) or automatically by a low-battery condition (see Section 2.4.8).

C - Indicates that a call has been received on a system/group programmed for a call indicator (see Section 2.4.2). This indicator is turned off by pressing any key.

Z - Indicates that the scan mode is selected (see Section 2.8).

U - Indicates that the displayed group is programmed for a LTR-Net auxiliary call (see Section 2.10.1).

Key Icon - Indicates that the current quick select switch position is locked and cannot be user programmed (see Section 2.5).

Phone Icon - When the base portion is displayed, the selected group is programmed for telephone calls (LTR-Net and LTR systems only). When the receiver portion of this icon is displayed, the phone mode is selected (see Section 2.7).

2.3 GENERAL OPERATION

2.3.1 BACKLIGHT OPERATION

The backlight automatically turns on for 3 seconds whenever any key is pressed or the quick select switch is rotated.

2.3.2 SYSTEM/GROUP DISPLAY MODE

The selected system and group is displayed in the alphanumeric section of the display. Two display formats can be selected. One is a numeric format and

the other is an alpha format (see next paragraph). The display is switched between these formats by pressing the ◀▶ key (standard models) or FCN ◀▶ (telephone keypad models). On power-up, the numeric format is always selected. In addition, the numeric mode is automatically selected with telephone keypad models whenever the group select key (GRP) is pressed.

When the numeric format is selected, the system and group numbers are displayed as “Sxx Gxx”, and the alpha tag, if programmed, is not displayed. When only group scanning is occurring, the group number is replaced by dashes and the system number continues to be displayed.

When the alpha format is selected, the system alpha tag is displayed and the system and group numbers are not displayed. When only group scanning is occurring, there is no special indication because the alpha tag continues to be displayed.

2.3.3 SYSTEM AND GROUP SELECT

With the standard model (without telephone keypad), only the quick select switch is used to select system/groups. Additional systems or groups cannot be selected by front panel keys. Up to 16 different system/group combinations can be selected, and the combination selected by each position can be set only by programming (see Section 2.5).

With the telephone keypad model, system/groups can be selected by the quick select switch and the front panel SYS and GRP keys (except when the quick select switch position is locked). Pressing the SYS or GRP key increases the selected system or group, and pressing FCN and then the SYS or GRP key decreases the selected system or group number. After the highest programmed system or group is selected, wrap-around to the lowest programmed system or group occurs and vice versa. If the key is held down, the function repeats. When the system is changed, the last selected group of the new system is displayed.

2.3.4 SQUELCH ADJUST

The squelch level is internally preset during alignment and cannot be changed by the user.

2.3.5 LTR-NET, LTR, AND CONVENTIONAL OPERATING MODES

Introduction

This transceiver can be programmed to operate in the LTR-Net, LTR, and conventional modes. Each selectable system can be programmed for one of these modes. The type of operation that is programmed is determined by the type of repeater equipment being accessed by that selectable system. The differences in operation are described in the following information and also noted elsewhere as required.

LTR-Net and LTR Operation

The LTR-Net mode provides the most operating features. Some features available only in the LTR-Net mode include roaming (automatic locality search), unique ID calls, and directed group calls. LTR-Net features are described in Sections 2.9 and 2.10.

Operation in the LTR mode is similar to the LTR-Net mode except that the preceding (and other) LTR-Net features are not available. The types of calls that can be placed in the LTR mode are standard group (mobile-to-mobile) and telephone. LTR features are described in Sections 2.9 and 2.11, and also the LTR Application Note, Part No. 009-0001-020, rev. 8 or later.

Both the LTR-Net and LTR modes provide automatic channel selection (trunking) and monitoring before transmitting. Special tones and display messages indicate busy and no access conditions, and telephone calls can be placed almost as conveniently as with your home telephone.

Selecting a system selects a locality, home repeater, collection of groups, and other information. Selecting a group selects the call type, transmit and receive ID code of the call, call indicator operation, and other information. The group call ID codes determine the mobile or group of mobiles being called and what calls are received.

Conventional Operation

In the conventional mode, selecting a system selects a block of up to 10 channels, and selecting a group selects a channel from that block. Each channel

(group) can be programmed for a different squelch control technique (CTCSS, DCS, or carrier) and other parameters. The squelch level is preset and cannot be adjusted by the user.

With conventional operation, an out-of-range condition is not indicated by a special tone or display message because there is no data handshake with a repeater that allows this condition to be detected. A busy condition is detected automatically if the Transmit Disable On Busy feature is used (see Section 2.12.2). Otherwise, it must be detected manually (see following). Refer to Section 2.12 for more information on conventional operation.

To manually monitor a conventional channel before transmitting to determine if it is being used by someone else, proceed as follows:

Using Busy Indicator - With scanning disabled and the desired group (channel) selected, note if the Busy indicator on the front panel is on. If it is, a carrier is being detected. If this indicator is not on, the channel is not busy and a message can be transmitted.

Using Monitor Mode - There may be times when the Busy indicator is on even if the channel is not busy (such as if the repeater has extended hang time). Monitoring can then be performed by pressing the upper AUX (Auxiliary) switch on the side. Pressing this switch toggles the monitor mode on and off (see Section 2.12.1). This mode is indicated by , and it disables scanning and Call Guard squelch so that all messages on the channel are heard.

2.3.6 LOCALITIES, SYSTEMS, AND GROUPS

When a call is placed, a system (locality) and group are selected. Definitions of each of these terms follow:

Localities

An LTR-Net or LTR locality is a repeater site. The repeaters are typically co-located and interconnected by a common bus to form a trunked channel group. Each locality can have up to twenty repeaters. With this transceiver, localities are not programmed separately. Instead, each system is programmed with locality as well as system information. Therefore, up to 14 localities can be programmed.

Since conventional repeaters do not have to be at the same site, localities do not really apply to conventional operation with this transceiver. Unique locality parameters include the repeater frequencies, status repeater (LTR-Net only), and what repeaters are equipped with telephone interconnect (LTR only).

Systems

LTR-Net and LTR systems are programmed with the status (LTR-Net only) and home repeater numbers, and fixed priority, selectable, and block decode ID codes. For more ID code information, refer to the following table and Section 2.9.1. In addition, blocks of RIC interconnect (LTR only) and transmit inhibit ID codes can be programmed.

LTR-Net and LTR System ID Codes

Decode (Receive)	Encode (Transmit)
Fixed Priority	
2	N/A
Selectable	
10	10
Block	
Up to all 239 (LTR-Net)	N/A
Up to all 250 (LTR)	

The home repeater number and group ID code form the address for group calls. The home repeater is monitored for incoming call information, and the status repeater serves as a backup with LTR-Net operation. Conventional systems are programmed with up to ten groups, each of which selects a unique radio channel (see next paragraph).

Groups

The groups assigned to a system select individual call information. Up to 10 groups can be programmed in each system. The types of calls programmable with each type of operation are as follows:

LTR-Net Calls

Standard Group - Used to place and receive standard mobile-to-mobile calls. Encode and decode IDs from 1-239 can be specified.

Telephone - Used to place and receive telephone calls. An encode and decode ID of 241 is entered with this transceiver to program this call type.

Auxiliary - Used to place unique ID and directed group calls. An encode and decode ID of 240 is entered with this transceiver to program this call type.

LTR Calls

Standard Group - Used to place and receive standard mobile-to-mobile calls. Encode and decode IDs 1-250 can be specified if accessing an LTR locality (site), and 1-239 if accessing an LTR-Net site.

Telephone - Used to place telephone calls. A RIC (interconnect) ID is specified. This code must be one that has been reserved on the locality (site) for telephone calls.

Conventional Calls

Only standard group calls can be programmed with conventional operation. Conventional groups select the radio channel, Call Guard squelch, and other information.

2.3.7 PLACING AND RECEIVING STANDARD GROUP CALLS

Standard group (dispatch) calls are between two or more mobile or control station transceivers. Unlike other types of calls, no number is dialed when the call is placed. The following procedure applies to all operating modes (LTR-Net, LTR, conventional). Proceed as follows to place and receive a group call:

Placing a Group Call

1. Turn transceiver power on and set the volume if necessary. Select the system and group of the mobile being called as described in Section 2.3.3.
2. If a conventional call is being placed, monitor the channel manually or automatically as described in Section 2.3.5.
3. The PTT (push-to-talk) switch on the side must be pressed (and held) to talk and released to listen. Operation with the different call types is as follows:

LTR-Net/LTR Operation

- If the proceed tone is enabled, it sounds when the system is successfully accessed (see Section 2.9.4).
- If all repeaters are busy, the busy tone sounds (see Section 2.13.1) and “BUSY” is indicated in the display. The PTT switch must then be released and pressed again to make another access attempt.
- If the system could not be accessed because of an out-of-range condition or some other reason, the intercept tone sounds and “NO ACCS” is indicated in the display. The PTT switch must then be released and pressed again to make another access attempt.
- When responding, busy or no access conditions may also occur as when placing a call because the system is accessed for each transmission.

Conventional Operation

- If the channel is busy and the Transmit Disable On Busy feature is programmed (see Section 2.12.2), the transmitter is disabled. While the PTT switch is pressed, monitoring is enabled so that the activity on the channel can be monitored.
 - Otherwise, busy and no access conditions are not indicated (see Section 2.3.5) and speaking can begin when the PTT switch is pressed. The proceed tone does not sound with conventional operation.
4. When the call is finished, the transceiver automatically returns to the standby mode.

Receiving a Standard Call

1. Turn transceiver power on and set the volume if necessary. Select or scan (see Section 2.8) the system and group programmed for the call you want to receive.
2. When the message is received, press the PTT switch on the side to talk and release it to listen. If scanning, a response may not automatically occur on the

group of call. Refer to Section 2.8.7 for more information.

2.4 GENERAL FEATURES

2.4.1 AUXILIARY SWITCH

The AUX (Auxiliary) switch is the upper switch on the side. This switch selects the monitor mode on conventional systems so that the channel can be monitored (see Section 2.3.5). In addition, pressing it while scanning is occurring momentarily halts scanning and displays the selected system/group number or system alpha tag. On all systems, rapidly pressing it twice toggles group scanning on and off (see Section 2.8.2).

2.4.2 CALL INDICATOR

The call indicator is the “**C**” icon in the upper part of the display. The purpose of this indicator is to show that a call was received while the user was away from the transceiver. It is turned off by pressing any key. If scanning is enabled and the HOME key is programmed to display the last active system/group, pressing that key displays the system/group on which a call was received.

With LTR-Net and LTR systems, the selectable and two fixed priority ID codes can be programmed to enable the call indicator. With conventional systems, each channel (group) can be programmed to enable the call indicator. If Call Guard squelch is programmed on a group, it must also be detected for the call indication to appear (unless Call Guard squelch is disabled by the monitor mode).

2.4.3 COMPANDING

The companding feature is standard with 900 MHz models and not available with 800 MHz models. It can be enabled on each LTR-Net, LTR, and conventional system by programming. It is not user selectable or indicated in the display. Companding improves audio quality by decreasing the amount of noise present in the audio signal. It does this by providing 2:1 compression of the transmit signal and 1:2 expansion of the receive signal.

If companding is used for mobile-to-mobile calls, it must be used in both the transmitting and receiving

mobiles. Better performance results if it is also used in the repeater. With telephone calls, it must be used at the repeater if it is used in the mobile.

2.4.4 EMERGENCY CALLS

Emergency calls are not available with this transceiver.

2.4.5 HOME KEY

The Home key function is available with telephone keypad models only, and it is selected by pressing FCN and then the HOME (3) key. Pressing this key temporarily displays either the home or last active system/group, depending on which it has been programmed to select (see following). The time it is displayed (Return Time) is programmable for 1-7 seconds. This function is disabled if the quick select switch is turned to a locked position (see Section 2.5).

When the HOME key is programmed to display the home system/group, the preprogrammed “home” system/group is displayed. If it is programmed to display the last active system/group, pressing it while scanning displays the last system/group on which a call was received or transmitted. If no call has been received or transmitted since scanning was enabled or if it is pressed when not scanning, it has no affect because the selected system/group is displayed.

A message can be transmitted on the system/group displayed by this key if the transmitter is keyed while it is displayed. However, if scanning and the “Last Selected” configuration described in Section 2.8.7 is programmed, the transmission occurs on the last selected system/group. When the return timer or scan delay timer expires, the last selected system/group is again displayed.

2.4.6 KEYPAD LOCK

Occasionally, the front-panel keys may be accidentally pressed. This could happen, for example, if the transceiver is carried on a belt and brushes against other objects. To prevent this from happening, all front panel keys except MENU can be disabled by the keypad lock feature. To enable this feature, select the menu mode by pressing FCN MENU and then the

◀▶ key and PTT switch to select “KP_LOCK” parameter. Refer to Section 2.6 for more menu mode information.

If a key is pressed with the keypad locked, all that happens is that “KP_LOCK” is indicated in the display. To re-enable the keys again, reselect the menu mode and select either “KP_ENAB” or “KP_MUTE”. The top and side panel controls remain functional with this feature selected. Turning power off and then on again does not change the keypad lock status.

2.4.7 KEY PRESS TONE

A short tone normally sounds when a front panel key and the AUX and FCN switches on the side are pressed. If desired, this tone can be disabled by the menu mode “KP_MUTE” parameter. Press FCN MENU to select the menu mode and then the ▶◀ key and PTT switch to select “KP_MUTE” (see Section 2.6). There is no indicator that shows that this tone is disabled. To enable the key press tone again, reselect the menu mode and the “KP_ENAB” parameter. Turning power off and then on again does not change the status of the key press tones. The key press tone is not heard by the receiving mobile when transmitting because the microphone audio signal is muted while it sounds.

2.4.8 LOW BATTERY INDICATOR

When the battery voltage drops below approximately 5.9 VDC, the amber low-battery indicator on the top panel lights. In addition, a beep sounds when this indication initially appears and when the push-to-talk switch is released (if the key press tone is enabled). Low transmit power indicated by “L” in the display is automatically selected when a low battery is being detected. If detection occurs while transmitting, low power is not selected until the PTT switch is released.

The battery should be recharged as soon as possible after this indication appears. If the battery voltage drops to the point where the transceiver no longer operates, all segments in the display are enabled. The low-battery indication is turned off by turning power off and then on again. The current settings of switches and other parameters are saved in memory at power turn-off in the normal manner during a low-battery condition.

2.4.9 POWER SELECT

The menu mode can be used to select high and low transmitter power output. The low output level is indicated by “L” in the display. Press FCN MENU to select the menu mode and then the ▶◀ key and PTT switch to select “LOPOWER” or “HIPOWER” (see Section 2.6). Turning power off and then on again does not change the selected power output level.

2.4.10 TIME-OUT TIMER

The Time-Out Timer disables the transmitter if it is keyed continuously for longer than the programmed time. It is programmed in half-minute increments from 0.5-5 minutes. If the transmitter is keyed for longer than the programmed time, the transmitter is disabled, the intercept tone sounds, and “TX TIME” is displayed. The timer and tone are reset by releasing the push-to-talk switch. The Time-Out Timer can prevent a repeater from being kept busy for an extended period by an accidentally keyed transmitter. It can also prevent possible transmitter damage caused by overheating.

2.5 QUICK SELECT SWITCH

2.5.1 STANDARD MODEL

With standard models (without telephone keypad), the quick select switch is always used to select systems/groups because there are no SYS and GRP keys. Up to 16 combinations of 14 systems and 10 groups can be programmed. For example, position 1 could select System 1/Group 1, position 2 System 1/Group 2, position 3 System 2/Group 1, and so on.

The quick select switch positions can be programmed only by the programmer (positions are not programmable by the user). When a position is locked by programming, the only affect is to cause the “Last Selected” configuration to always be active when scanning (see Section 2.8.7).

When system or group scanning, only the systems and groups programmed for the switch positions are scanned because those are the only system/groups transferred into the transceiver by the programmer.

2.5.2 TELEPHONE KEYPAD MODELS

General

With the telephone keypad models, both the quick select switch and the SYS and GRP keys can be used to select systems and groups (see Section 2.3.3). The switch can be used as a “quick select” and the keys can be used for scrolling. Therefore, the selected system/group may not be the one programmed for the current quick select switch position. If the quick select switch is turned while transmitting, the system/group does not change until the PTT switch is released. The system/group also does not change if a position has not been programmed or is programmed with an invalid system/group.

Each quick select switch position can be locked by programming. When a locked position is selected,  is displayed and the SYS and GRP keys are disabled. This ensures that the system/group programmed for a position is always selected. This is especially useful when the display cannot be viewed, such as when carrying the transceiver on a belt. In addition, locked positions cannot be reprogrammed by the user. Refer to the following for more information.

Programming Quick Select Switch

If the transceiver is equipped with the telephone keypad, any quick select switch position not locked by programming can be reprogrammed from the front panel as follows:

1. Set the quick select switch to the position to be programmed.
2. Select the system/group for that position by pressing the SYS and GRP keys. If these keys do not function, the switch position or the keypad is probably locked.
3. Press FCN STR to program the position. If “LOCKED” is displayed and a beep sounds, the switch position is locked and cannot be reprogrammed.

2.5.3 OPERATION WITH A LOCKED POSITION SELECTED (ALL MODELS)

LTR-Net roaming (see Section 2.10.3) is not disabled when a locked position is selected. Therefore, if roaming to another locality occurs, the displayed system can change even if the position is locked. When scanning is enabled with a locked position selected, the “Last Selected” configuration described in Section 2.8.7 is always automatically selected even if the “temporary” configuration is programmed. If this did not occur, a transmission could occur on some system/group other than the selected. This affects operation only if the PTT switch is pressed with scanning halted.

If an LTR-Net or LTR fixed priority call is received with a locked position selected, the transceiver may switch to another group as described in Section 2.9.1. However, the transceiver stays on that system/group only until the PTT switch is pressed, scanning resumes (if applicable), or the system/group is changed manually.

2.6 MENU MODE

The menu mode can be used to select the following functions:

- Power output level
- Keypad lock and key press tone disable
- Proceed (clear-to-talk) tone on/off and level
- Display current software version number

To use the menu mode, proceed as follows:

1. To select the menu mode, press FCN button on the side and then the MENU key. If the menu mode is selected while receiving a call, the call is interrupted.
2. Press the ◀▶ key to display the desired parameter group from the three which follow. The currently selected parameter in each group is displayed. Press the PTT switch to select some other parameter.
3. To save the displayed configuration of each group and resume normal operation, press FCN. This also occurs automatically if no key is pressed for 3 seconds.

The parameters and the available configurations for each are as follows:

HIPOWER - High power (Section 2.4.9)

LOPOWER - Low power

KP_LOCK - Keypad disabled (Section 2.4.6)

KP_ENAB - Keypad and key press tones enabled

KP_MUTE - Keypad enabled, key press tones disabled (Section 2.4.7)

PTT_0TN - Proceed tone disabled

PTT_1TN - Single (soft) proceed tone

PTT_2TN - Dual (loud) proceed tone



56522xx - The “2xx” indicates the version of operating software in the transceiver.

NOTE: The proceed tone is not available on conventional systems (Section 2.9.4).

For example, to disable the keypad, select the menu mode and then press the ◀▶ key to select the “KP_xxxx” group. Then press the PTT switch to display “KP_LOCK”. If FCN is then pressed or when normal operation resumes in 3 seconds, the keypad will be locked. Turning power off does not change selected menu mode parameters.

2.7 PHONE MODE

2.7.1 GENERAL

The phone mode is available with telephone keypad models only. It is selected by pressing the FCN switch on the side and then the PHON (1) or SND (SCAN) key as describe in the next section. The phone mode is enabled when the telephone receiver icon () is displayed (the base  indicates that a telephone group is selected).

The phone mode provides the following features which make placing telephone calls more convenient:

- The system/group number or alpha tag in the alphanumeric display is cleared so that the dialed telephone number can be displayed.
- The SYS, GRP, and SCAN keys become, respectively, RCL, CLR, and SND. In addition, FCN STR

changes from quick select switch programming to telephone number memory store.

- Numbers can be entered at any convenient rate and then transmitted automatically when desired by pressing the SND key.
- Up to six 14-digit telephone numbers can be stored in memory and recalled as needed.
- System and group scan are disabled. Therefore, calls are received on only the current system and group (and also any priority or block decode codes if programmed).

Other phone mode highlights are as follows:

- Telephone calls can be placed without selecting the phone mode by simply pressing the push-to-talk switch and dialing the number. However, the dialed number does not appear in the display and therefore cannot be stored or recalled. When calls are received, selection of the phone mode is optional because it does not enhance operation.
- Only the quick select switch can be used to change the system and group in the phone mode because the SYS and GRP keys are RCL and CLR keys. Changing the system/group does not affect the phone mode which remains selected.
- Although the phone mode is intended for use in making LTR-Net and LTR telephone calls, it can also be used for LTR-Net Unique ID and directed group calls and in the conventional mode.
- The main difference in operation in the conventional mode is when the telephone number can be sent using the SND key. When a LTR-Net or LTR system is selected, the dial tone must first be obtained by briefly pressing the push-to-talk switch. The transceiver detects the probable presence of this tone by detecting when receive audio is enabled.
- When a conventional system is selected, the telephone number can be sent at any time as long as no carrier is detected. If a carrier is being detected, the SND key is active only if the monitor mode is enabled. This ensures that the channel is monitored.

2.7.2 SELECTING AND EXITING THE PHONE MODE

As stated earlier, the phone mode is entered by pressing FCN PHON or FCN SND. Slightly different operation is selected by each as described in the following information. The phone mode is exited by pressing FCN PHON or cycling power.

FCN PHON - The displayed system and group do not change when the phone mode is entered and exited. For example, if System 2/Group 4 is displayed before the phone mode is selected, the transceiver remains on that system/group in the phone mode and also after the phone mode is exited by pressing the FCN PHON.

FCN SND - The system/group programmed for telephone calls is automatically selected. Then when the phone mode is exited by pressing FCN PHON, the last selected system/group is displayed. If the quick select switch was not changed while in the phone mode, this is the system/group that was displayed before the phone mode was entered. If the quick select switch was changed, it is the system/group selected by that switch.

NOTE: The phone mode cannot be selected by FCN SND if the quick select switch is on a locked position.

2.7.3 ENTERING THE TELEPHONE NUMBER

Erase last digit - CLR (hold key down to repeat).
Erase entire number - RCL CLR
Display overflow digits - RCL ◀▶

With the phone mode selected, the telephone number can be entered at any convenient rate, dialing errors corrected, and then the number transmitted when desired by pressing the SND key (after acquiring a dial tone by pressing the PTT switch). Digits are erased as indicated below.

Numbers up to 14 digits in length can be entered. However, digits 8-14 scroll out of the display. To momentarily display the overflow digits, press RCL ◀▶ (0) as indicated below. Another number can be dialed without changing the number in the display by simply pressing the push-to-talk switch while dialing the number.

2.7.4 STORING AND RECALLING NUMBERS

Storing A Number

Store a Number - FCN STR + location no. (1-6)

Up to six 14-digit numbers can be stored in memory and later recalled. To store a number, select the phone mode and enter the number as described in the preceding section. Then press FCN STR and the location number from 1-6 of where the number is to be stored as shown below. If an invalid location is entered (a number other than 1-6) or if the location is locked by programming (see “Storing Numbers Using Programmer” which follows), an error tone sounds.

The * character is stored and sent normally without a pause. You may not want to store the # character because it may terminate the call with some interconnect equipment (such as LTR RIC). If there already is a number in the specified location, it is replaced by the new number.

Recalling A Number

Recall a Number - RCL + location no. (1-6)

To recall a number from memory, press RCL (SYS) and the location number from 1-6 as shown below. The number is then displayed and it can be changed if desired and then transmitted by pressing SND. When numbers longer than 7 digits are recalled, digits 8-14 are displayed for 2 seconds and then digits 1-7 are displayed continuously. To momentarily re-display digits 8-14, press RCL ◀▶.

A number can also be recalled from memory after the connection is made and then dialed automatically by pressing SND. One use of this feature is to allow a credit card number to be stored in memory and then sent automatically.

Storing Numbers Using Programmer

Any of the six memory locations can also be programmed by the programmer. When this method is used, unused digits can be programmed with a unique identification or other information that is flashed in the display before the telephone number is displayed.

For example, if a seven digit telephone number is programmed, the first seven positions could be programmed with a non-numeric identification such as "RICHARD" and the last seven positions could be programmed with the telephone number. Then when this number is recalled, "RICHARD" is flashed in the display followed by the telephone number.

When a number programmed this way is transmitted, all characters except 0-9, "*", and "#" are ignored. Therefore, various configurations of characters can be programmed as long as the phone number digits are in the correct order. Each number can also be locked so that it cannot be reprogrammed by the user. If a number with alpha characters is changed by the user, the alpha characters are erased and can be reprogrammed again only by the programmer.

Scrolling Through Memory

Scroll Through Programmed Numbers - RCL RCL

The RCL (SYS) key can also be used to step through the programmed numbers. If RCL is pressed twice, the scroll mode is selected. If the display was blank when it was pressed, the number in location 1 is displayed. If the display contains a number, the number in the next higher location is displayed.

The first press displays the upper seven characters and the second press displays the lower seven. Then pressing it again displays the number in next location in the same manner and so on. Empty locations are displayed as blank digits. If RCL is not pressed the second time, the first seven characters are displayed for 2 seconds and then the lower seven characters are displayed continuously.

2.7.5 TERMINATING A CALL

When a conversation is finished, the call should be terminated. This is usually done in the phone mode by pressing the # key (* # may also be used). The # character is also sent automatically when the phone mode is exited by pressing FCN PHON. If not in the phone mode, these characters can be sent by pressing the PTT switch and the desired key. Three beeps indicate that the call has been terminated

Terminating the call tells the switch or RIC unit that the call is finished. If the call is not terminated in this manner, the repeater or repeaters being used are held until the end of the call is automatically detected. Additional billing then occurs for this time.

2.8 SYSTEM AND GROUP SCAN

2.8.1 SYSTEM SCANNING

System scanning is turned on and off by pressing SCAN (telephone keypad models) or FCN SCAN (standard models). The scan mode is indicated by  in the display. System scanning is available on LTR and conventional systems, but not LTR-Net systems as described in Section 2.8.4. When system scanning is actually occurring with an LTR or conventional system selected, "IN SCAN" is displayed. Scanning is sequential through all programmed systems unless they are deleted from the scan list as described in Section 2.8.5. If system scanning is not enabled, calls are detected on only the selected system.

2.8.2 GROUP SCANNING

With LTR-Net and LTR operation, group scanning is enabled or disabled on each system by programming. It is then automatically selected whenever the system is selected or scanned. If the numeric display mode is selected (see Section 2.3.2), group scanning is indicated by dashes in place of the group number (G --). If the alpha tag mode is selected or system scanning is enabled, group scanning is not indicated.

To toggle group scanning on and off, press the AUX switch on the side twice within 1 second. Group scanning can be toggled by this switch only if group scanning has been enabled on the system by programming. The enabled mode is always selected when power is turned on.

When group scanning is enabled on LTR-Net and LTR systems, calls are detected on all selectable groups of a system regardless of which is selected. When group scanning is disabled, calls are detected on only the selected group, or on the last selected group if system scanning. With conventional systems, group scanning is not available, so calls are always detected on only the last selected group.

On LTR-Net and LTR systems programmed with fixed priority and block ID codes, calls on those codes are detected regardless of group scan programming (as long as the system programmed with those codes is selected or scanned). The priority order is the same as when not scanning (see Section 2.9.1).

2.8.3 GENERAL SCANNING INFORMATION

When an incoming call is detected that the transceiver is programmed to receive, scanning stops and the display indicates the system and group number or system alpha tag on which the call is being received. Shortly after the message is complete, scanning resumes and "IN SCAN" is again displayed (unless scanning has been disabled). The length of this delay is set as described in Section 2.8.6.

The selected system or group can be changed while scanning by simply pressing the SYS or GRP key or turning the quick select switch. This also halts scanning for the receive delay period. The display mode can be changed while scanning by pressing FCN ◀▶ (see Section 2.3.2). The AUX switch on the side can be pressed to temporarily halt scanning and display the selected system/group number or alpha tag.

When scanning is occurring, transmissions always occur on the selected system/group. However, when a message is received, scanning temporarily halts and the system/group of the call is displayed. A response may then occur on the displayed or selected group, depending on scan revert programming. Refer to Section 2.8.7 for more information.

2.8.4 SCAN OPERATION IN VARIOUS MODES

LTR-Net Mode

LTR-Net systems are not scanned by the system scan feature. When an LTR-Net system is selected, calls are detected on only the locality and groups of the current system (and any fixed priority and block ID codes) regardless of the currently selected scan mode. No other LTR-Net, LTR, and conventional systems are scanned. If the selected system is an LTR or conventional system, LTR-Net systems are not scanned (see following information). When scanning is initially selected on an LTR-Net system, locality search may occur (see Section 2.10.3).

If group scanning is programmed on selected LTR-Net system and the transceiver is a telephone keypad model, the group scan list is user programmable. Group scan list programming is not available with the standard models. Refer to Section 2.8.5 for more information.

LTR Mode

If scanning is enabled and an LTR system is selected, all LTR and conventional systems in the scan list are scanned. The home repeater of each LTR system in the scan list is monitored. Each home repeater is monitored for only as long as necessary to detect all calls on that repeater. As noted in the preceding LTR-Net description, system scanning does not occur if an LTR-Net system is selected.

The LTR and conventional system scan list is user programmable (see Section 2.8.5). In addition, if group scanning is programmed on selected or scanned LTR systems (see Section 2.8.2) and the transceiver is a telephone keypad model, the group scan list is user programmable. Group scan list programming is not available with the standard models and on conventional systems. Priority and block ID calls are also detected on all scanned LTR systems if programmed.

Conventional Mode

If scanning is enabled and a conventional system is selected, all conventional and LTR systems in the scan list are scanned. On conventional systems, calls are detected on only the last selected group (channel) of each system in the scan list. Calls are not detected on the other groups because group scanning is not available (see Section 2.8.2). Call Guard squelch is also detected except when the monitor mode is enabled (see Section 2.12.1). As noted in the preceding LTR-Net description, system scanning does not occur if an LTR-Net system is selected. The conventional and LTR system scan list is user programmable as described in Section 2.8.5.

A feature called Adaptive Tone Scan (ATS) is used when scanning conventional channels. If no carrier is detected, the channel is scanned for only 40 ms. If a carrier is detected, searching for Call Guard signaling occurs (if programmed). If the tone type of Call Guard squelch is programmed, the channel is

monitored for 180-420 ms. The shorter time is when the tone is outside certain limits, and the longer time is if it is at or near the programmed value. If digital type is programmed, approximately 350 ms is required to determine an invalid code (less time is usually required to detect valid codes).

2.8.5 SCAN LIST PROGRAMMING

General

The LTR and conventional system scan lists are programmable with all models of this transceiver. The LTR-Net system scan list is not programmable because LTR-Net system scanning is not available as just described.

The group scan list is programmable on LTR-Net and LTR systems if (1) the transceiver is a telephone keypad model and (2) group scanning is programmed on the system. It is not available on conventional systems (because group scanning is not available) or with any standard model or this transceiver.

A system or LTR-Net/LTR group can be deleted from the scan list while listening to a message by simply pressing the appropriate key (see following information). The system or group is deleted and scanning resumes when the receive delay time expires.

The system scan list is stored in memory at normal power off, and the group scan list is stored whenever it is changed. Therefore, turning power off does not change the scan list. If all programmed systems are deleted, an error tone sounds and all systems are automatically added into the scan list.

Scan List Indicators

The scan list indicators are “S” and “G” in the display when scanning is disabled (“Z” not displayed). When the displayed system is in the scan list and scanned normally, “S” is displayed. Likewise, when the displayed group is in the scan list and scanned normally, “G” is displayed.

Standard Model Scan List Programming

With the standard model (without telephone keypad), only the system programmed for each quick

select position can be deleted. Therefore, if several switch positions are programmed with groups of the same system, all those switch positions are deleted. For example, if positions 1, 2, and 3 are programmed with groups 1, 2, and 3 of System 1, deleting position 1 also deletes positions 2 and 3 because they are programmed with the same system.

To add all deleted quick select switch positions back into the scan list, press FCN and then hold the A/D key for at least 2 seconds. LTR-Net group scan list programming is not available with standard models.

Telephone Keypad Model Scan List Programming

With telephone keypad models, the scan list status of the displayed system is changed by pressing FCN S.A/D key. Likewise, the status of a displayed LTR-Net or LTR group is changed by pressing the FCN G.A/D key. If an attempt is made to delete a conventional group, or a LTR-Net or LTR group when group scanning is not programmed, an error tone sounds.

Deleting a system only deletes the groups in that system until the system is added back into the scan list. To add all programmed systems back into the scan list, press FCN and then the S.A/D key for at least 2 seconds. Likewise, to add all deleted groups of a system back into the scan list, press FCN and then G.A/D for at least 2 seconds.

2.8.6 SCAN DELAY TIMERS

Receive Delay Timer

NOTE: Programming “8 seconds” for this parameter also selects the “last received” revert configuration described in Section 2.8.7.

When a message is received in the scan mode, there is a programmable delay of 1-8 seconds before scanning resumes. This delay is called receive delay time, and it prevents another message from being received before a response can be made. This delay is also in effect if a control is changed while scanning such as selecting another system or group. This timer is reset each time another call is received or if any front panel key is pressed. This timer and the

following call delay timer are radio parameters. Therefore, the same setting is used for all systems and groups.

Call Delay Timer

The preceding receive delay time controls the scan delay until the transmitter is keyed and then the call delay time controls the delay. This time is also programmable for 1-8 seconds, and it ensures that a response to your message is heard instead of some other message occurring on some other system or group. This timer remains active for the remainder of the conversation, and controls when normal scanning resumes, even if additional responses are received.

2.8.7 TRANSMITTING WHILE SCANNING

When the transmitter is keyed in the scan mode, Revert programming determines if the transmission occurs on the last selected or last received system/group. The display normally indicates the system/group on which the call is being received, but this may not be the system/group on which a transmission occurs (see following).

When LTR-Net roaming occurs, the selected system/group changes automatically regardless of Revert programming. In addition, when an LTR-Net or LTR priority call is received (see Section 2.9.1), this parameter determines if a response occurs on the selected or received group.

The three programmable configurations are as follows:

Last Selected - With this configuration, the transceiver always transmits on the last system/group that was manually selected by the quick select switch or SYS and GRP keys. To respond to a call not on the selected system and group, one of the following methods can be used:

- Select the system/group of the call manually.
- Before scanning resumes, turn off scanning. The system/group of a call then becomes the selected system/group and it is not necessary to change it manually.

Temporary - With this configuration, a response can be made to the call without having to change the selected system/group as long as it occurs before the scan delay expires (see Section 2.8.6). If the transmitter is keyed after the delay expires, transmissions occur on the selected system/group (which does not change when a call is received). However, if the current quick select switch position is locked, responses occur on the switch system/group, even if this configuration is programmed (see Section 2.5).

Last Received - With this configuration, the selected system/group changes to the system/group of a call. Responses can then always be made to a call without having to change the system/group. This configuration is selected by programming a Receive Delay Time of 8 seconds as described in Section 2.8.6. If the current quick select switch position is locked, responses occur on the switch system/group, even if this configuration is programmed.

2.9 LTR-NET AND LTR FEATURES

2.9.1 RECEIVE PRIORITY ID CODES

When receiving standard group calls, the fixed, selectable, and block ID codes have a priority order so that an incoming call with a higher priority ID code can interrupt a lower priority call in progress. One use of receive priority is to allow a dispatcher to interrupt calls in progress with an important “all call” message. If the transceiver detects a call with a higher priority ID than the one it is receiving, it immediately drops that call and switches to another repeater to receive the higher priority call. Telephone and special calls are not interrupted by priority calls.

The priority order of the decode ID codes is as follows:

1. Fixed Priority ID Code 1
2. Fixed Priority ID Code 2
3. Selected ID Code
4. Other Selectable ID Codes (w/grp scan)
5. Block ID codes

NOTE: A call on the selected group interrupts a call on some other selectable group only if “last selected revert” is programmed (see Section 2.8.7).

For example, if a call is being received on selectable group 4 and a call is detected on fixed priority ID 2, the call on group 4 is immediately dropped and the transceiver switches to the call on fixed priority ID 2.

When call is detected on a fixed priority ID code, the selectable ID codes are checked to see if any are the same. If a match is found, the transceiver changes to that group. If no match is found, it does not change. "RX PRI1" is then displayed if it is on priority ID 1, and "RX PRI2" is displayed if it is on priority ID 2. The programming of the "Revert" feature (see Section 2.8.7) determines if the change to the priority group is temporary or permanent and if a transmission occurs on the priority group.

With LTR-Net operation, incoming call information is received on the repeater to which the mobile is trunked as well as the home and status repeaters. Therefore, priority calls are detected when trunked to other repeaters.

With LTR operation, incoming call information is received on only the home repeater. Therefore, priority calls are not detected while trunked to some other repeater. To reach most mobiles with a priority message, the operator can key the transmitter and then not begin speaking for several seconds. This allows trunked-out mobiles time to finish the transmission and return to the home repeater.

This still may not reach mobiles making telephone calls and LTR-Net auxiliary calls because they hold a repeater for the duration of a conversation (instead of the duration of the transmission as with standard dispatch calls). Other times when priority calls can be missed with both types of operation are when transmitting and when some other system not programmed with the priority ID is being monitored.

2.9.2 BLOCK ID CODES AND ACCESS PRIORITY

LTR-Net and LTR systems can be programmed with a block of decode ID codes that includes up to all 239 (LTR-Net) or 250 (LTR) that are programmable. When a call is received on a block ID, the selected system/group does not change and "BLK" is displayed in place of the group number. Therefore, to respond to call on a block ID, the group programmed with that ID may need to be selected. If none is programmed with

that ID, a response is not possible unless the LTR-Net directed group call can be used (see Section 2.10.1).

Access priority is not available with this transceiver. This feature controls which transceivers can access the system during busy periods. The preceding section describes receive priority which controls which calls are received.

2.9.3 STANDARD GROUP CALLS

Standard group (dispatch) calls are between mobiles or groups of mobiles which use the standard group ID codes from 1-239 (LTR-Net) or 1-250 (LTR) that are assignable on each home repeater. LTR-Net and LTR standard calls are very similar and are placed and received using the same procedure. Simply select a group programmed with the ID code of the mobile being called and then press the PTT switch. No number is dialed with a keypad as with telephone or special calls.

To receive a standard group call, the group programmed with the ID code being transmitted must be selected or scanned. Calls with a higher priority than the selected group may also be received as described in Section 2.9.1. The procedure used to place and receive standard group calls is described in Section 2.3.7.

2.9.4 PROCEED (CLEAR-TO-TALK) TONE

The Proceed Tone is a short tone that sounds shortly after the push-to-talk switch is pressed to indicate that the system has been accessed (handshake completed) and speaking can begin. This feature is available on LTR-Net and LTR systems only. It does not sound with conventional calls. The menu mode PTT_xTN parameter (see Section 2.6) can be used to disable this tone entirely (PTT_0TN) or select a standard (PTT_1TN) or loud (PTT_2TN) tone.

If a busy condition is encountered, the busy tone sounds instead of the proceed tone and "BUSY" is displayed. The push-to-talk switch must then be released to make another call attempt. If an access attempt is unsuccessful, such as because of an out-of-range condition, the intercept tone (see Section 2.13) sounds instead of the proceed tone and "NO ACCS" is displayed.

2.9.5 TRANSMIT INHIBIT

This feature prevents the transmitter from keying if the mobile being called is busy with another call. To enable this feature, the LTR-Net or LTR system is programmed with a block of transmit inhibit ID codes that can include all 239 or 250 that are assignable on a home repeater. If a code within this block is detected up to 5 seconds before the push-to-talk switch is pressed, the transmitter does not key, "TX INHB" appears in the display, and the intercept tone sounds.

The 5-second counter does count down while the push-to-talk switch is pressed. However, to make another call attempt, the push-to-talk switch must be released and then pressed again.



This feature also prevents accidental interruption of a call in progress. This could happen when the transmitting party unkeys. It also provides an indication that the mobile being called is busy. A similar Transmit Disable On Busy feature is available on conventional systems.

2.10 LTR-NET FEATURES

2.10.1 SPECIAL CALLS

Introduction

Both standard and special calls can be placed and received with LTR-Net operation. Standard group calls were described in Section 2.9.3. The special calls originated by the mobile include Telephone and Auxiliary (see following information).

When a group programmed for Telephone calls is selected, the base of the telephone icon  is displayed (the handset  indicates when the phone mode described in Section 2.7 is selected). Then when a group programmed for Auxiliary calls is selected (either unique ID or directed group), "U" is displayed in the upper part of the display.

Most other special calls such as Interrogate, Mobile Disable, and Reassignment are originated by the system operator or a dispatcher. Special LTR-Net calls use the special call group ID codes from 240-254. The telephone keypad model of this transceiver and special programming are required to place special calls.

Mobile-Originated Special Calls

Telephone (Telco) - These are interconnect calls to or from a mobile made through the Public Switched Telephone Network (PSTN).

Auxiliary - These calls allow a mobile to communicate with specific mobiles or groups at the same locality (site) or another LTR-Net locality (when several LTR-Net repeater systems form a network). Calls to specific mobiles are called Unique ID calls, and calls to specific groups are called Directed Group calls.

Directed Group calls allow communication with groups that are otherwise not accessible because no selectable system/group has been programmed with the home repeater or group ID of those mobiles. Directed Group calls can be made to any home repeater on any group ID code from 1-239.

Transceiver Programming For Special Calls

To originate a special call and then respond, the selected group must be programmed with the ID code for the special call being made (Telephone or Auxiliary). Both the decode and encode IDs must be programmed with this ID code (see following chart).

Type of Call	Originating Mobile Encode/Decode ID	Receiving Mobile Decode/Encode ID
Telephone	ID Code 241	ID Code 241
Auxiliary		
Unique ID	ID Code 240	ID Code 240
Dir Group	ID Code 240	Group ID
Auxiliary Calls = ID 240; Telephone Calls = ID 241		

To receive Telephone and Unique ID calls and then respond, one of the selectable groups must be programmed with the ID code for the applicable call (Telephone or Auxiliary). These calls are received regardless of which group is selected or group scan programming. All that is required is that a group be programmed for the call and the system be selected or scanned. The transceiver temporarily or permanently changes to the group programmed for the call depending on scan revert programming (see Section 2.8.7).

To receive a Directed Group call and respond, a selected, priority, or scanned group must be programmed for the group ID specified by the originating

mobile. This is because the call is converted to a standard group call by the switch.

To receive landside originated telephone calls, the transceiver must be programmed for telephone calls even though the unique ID of the mobile may be specified when placing the call (see “Landside-Originated Calls” which follows).

Special Call Authorization

When a mobile is programmed to make Telephone calls, system authorization is needed before service is available. This authorization is performed by the system operator through the System and Subscriber Manager, and it determines what type of service is available. For example, a mobile may be authorized to dial local numbers only. This authorization is keyed to the mobile’s unique ID which is transmitted when any call is made.

Authorization is also required to make auxiliary calls. Unique ID calls can be made to any mobile in the same locality (site) or some other locality that is programmed for Auxiliary calls. The same applies to Directed Group calls except that the mobile receiving the call does not need to be programmed for Auxiliary calls, just the standard group ID being transmitted.

Placing a Special Call

NOTE: The phone mode described in Section 2.7 can also be used to place these calls.

The following is the procedure for placing a special call. Only models with the front panel telephone keypad can place these calls.

1. Select the group programmed for Telephone or Auxiliary calls, whichever is to be made. When a group programmed for telephone calls is selected,  is displayed, and when a group programmed for Auxiliary calls is selected, “U” is displayed in the upper part of the display.
2. Press the PTT switch and when the system is accessed, the proceed tone sounds (if it is enabled). Release the PTT switch and a dial tone should be heard. Busy conditions and successful and unsuccessful

accesses are indicated as described in Section 2.3.7. If an telephone call is being placed, dial the telephone number of the landside party you are calling.

3. If a unique ID or directed group call is being made, a 1-10 digit number is dialed which specifies the destination of the call. This number is entered the same as with telephone calls. The digits dialed for the various types of calls are as follows:

Unique ID Call (Current Locality)

1-5 digit unique ID of mobile/dispatcher

Unique ID Call (Directed Locality)

3-digit locality ID +

5-digit unique ID of mobile/dispatcher

Directed Group Call (Current Locality)

3-digit home repeater number +

3-digit group ID

Directed Group Call (Directed Locality)

3-digit locality number +

3-digit home repeater number +

3-digit group ID

Unique ID Call (Using Telephone Number)

10-digit telephone number or mobile being called

NOTE: Mobile-to-mobile unique ID calls can also be placed by dialing the mobile’s telephone number if it has one.

4. Release the PTT switch if it was pressed to dial the number. A beep should then sound which indicates that the number was accepted by the system. If this beep does not sound, an unauthorized number may have been dialed or a dialing mistake may have been made. If a system resource busy condition exists, the call is placed in a queue by the system (see Section 2.10.2).
5. The various types of calls then proceed as follows:

Telephone Call - The normal landside ringing or busy tone is heard. When the party answers, press the PTT switch to talk and release it to listen as with standard calls.

Unique ID Call - A “ringing” tone is heard which indicates that the mobile is being rung. If there is no answer, ringing stops after several rings or the call can be terminated by pressing the # key. When the party answers, press the PTT switch to talk and release it to listen as with a standard call.

Directed Group Call - A second beep sounds which indicates that the path to the mobile is complete and speaking can begin (no ringing of the other mobile occurs). Press the PTT switch to talk and release it to listen.

NOTE: Since this transceiver operates half-duplex, you cannot hear the other caller while transmitting or speak to the other caller while receiving.

6. When the call is finished, terminate it by pressing the # key (* # may also be used as described in Section 2.7.5). This tells the system that the call is complete and prevents additional billing for the time required by the system to automatically detect the end of the call.

Receiving Special Calls

To receive a special call, all that is required is that the system programmed for the special call be selected (see information at the beginning of this section). When an Telephone or Unique ID call is received, “ringing” is heard. If it is a Directed Group call, only the voice of the calling party is heard because no ringing occurs.

Landside-Originate Special Calls

Calls can be also be made from any landside telephone to specific mobiles (Unique ID calls) or groups (Directed Group calls). Calls can also be placed to other sites similar to when they are mobile dialed.

If the system has DID lines, the landside caller can dial a mobile directly because each mobile that can receive these calls is given its own phone number. If the system has standard trunk lines, the telephone number of the system is dialed. Then when the system answers, a short tone sounds to indicate that the digits specifying the destination of the call should be dialed. The same digits are dialed as described in “Placing a Special Call”. The landside telephone must produce standard DTMF tones to dial these digits.

After these digits are dialed, a beep is heard which indicates that the number was accepted by the system. Ringing then indicates that the mobile is being rung unless it is a Directed Group call. With those calls, no ringing of the mobile occurs and another beep is heard which indicates the path is complete and speaking should begin.

After the mobile answers, the landside party should respond in the normal manner. Remember that the mobile is operating half duplex and cannot hear the landside party while transmitting. When the call is finished, it should be terminated by the mobile party. Three beeps indicate that the call has terminated.

2.10.2 BUSY QUEUING/FREE SYSTEM RINGBACK

This transceiver does not have a feature that places a call in a queue if all channels are busy. In addition, it does not have a free system ringback feature that alerts the user when the repeater system is no longer busy.

However, busy queuing may be provided at the system level for telephone, unique ID, and directed group calls (not standard group calls). If this feature is enabled by the System and Subscriber Manager and resources are not available when one of these calls are placed, a voice message informs the user that the call has been placed in a queue. This message occurs when the PTT switch is released after dialing the digits.

If resources then become available, the call is automatically placed and the normal ringing or beep tones are heard. If the call cannot be placed in the allotted time, it is terminated and another voice message informs the user that this has occurred.

2.10.3 ROAMING (AUTO-REGISTRATION)

General

NOTE: Roaming is always enabled when an LTR-Net system is selected (there is no on-off control).

The roaming (auto-registration) feature permits all types of LTR-Net calls to be automatically routed to the LTR-Net locality (site) in which the mobile is operating. To utilize roaming, all that is required is that an LTR-Net system be selected. Scanning does not

need to be enabled. However, if it is enabled, an LTR-Net system must be selected. If an LTR or conventional system is selected, roaming is disabled and LTR-Net systems are not scanned.

Registering on a New Locality

When roaming is initially enabled or power is turned on, the status channel of the currently selected system is monitored for a free channel. When one is decoded, a registration message is sent. This message includes the mobile's unique ID and the home repeater to be used. The registration information is forwarded to the System and Subscriber Manager which then knows its location.

If the signal from a locality is weak (see Dropout and Capture Criteria which follows), or if two unsuccessful access attempts are made with the double no access feature enabled (see Table 3-1), the transceiver begins searching for another locality. When this is occurring, "LC SRCH" is displayed.

Up to five preferred localities can be programmed (see Table 3-2). These localities are always searched first and in the programmed order when automatic locality search is initiated. If none of the preferred localities could be accessed or none are programmed, the other programmed LTR-Net localities are searched. Over-the-air programming can be used to add or change but not delete preferred localities.

NOTE: De-registering does not occur with this radio.

Revert System/Group Selection After Registration

After registration on a new locality occurs, "LC SRCH" is no longer displayed, and the system of the accessed locality is displayed. If one of the preferred localities is accessed, it is the system of that locality. Otherwise, it is the next higher system programmed with the locality that could be accessed (wrap-around occurs after the highest system is checked). The selected group is the last selected group of that system. A call can be received on a new locality before registration occurs if the call is already active on that locality.

Dropout and Capture (Pick- Up) Criteria

The receive signal level at which registration on another locality is triggered is controlled by a program-

mable system parameter called Dropout Criteria. This parameter is programmable for 50-100% with a default setting of 75%. This parameter sets the percentage of good data messages that must be received over a sampling period to avoid entering the task that searches for a new locality. Therefore, the higher the programmed percentage, the sooner roaming occurs.

The receive signal level that must be detected on a new locality before registration is attempted is controlled by a programmable system parameter called Capture (Pick-Up) Criteria. It is programmable for 50-100% with a default setting of 80%. This parameter sets the percentage of good data messages that must be received over a sampling period. Therefore, the higher the percentage, the stronger the signal must be for registration to be attempted. Note that the transceiver uses the value programmed for the locality being sampled, not the value programmed for the locality on which it is currently registered.

The difference between the Dropout and Capture Criteria percentages establishes a signal hysteresis between the current and a new locality. The Capture percentage should be set higher than the Dropout percentage. This prevents registration on a new site with a weaker signal than the current site. It also prevents registration on the same site that was lost.

2.10.4 OVER-THE-AIR LOCALITY CHANNEL UPDATES

Localities (systems in this transceiver) are initially programmed with the channel numbers of all repeaters currently in use. These are then the channels that the transceiver can access when placing and receiving calls. If new channels are later added to a locality, over-the-air programming is used to update the transceivers with the new channels. This eliminates the need to bring them in for reprogramming. Channel updates occur on only selected repeaters, and they are initiated automatically by the radio system. While channels are being updated, "PROG CH" is displayed.

2.10.5 TRANSCEIVER DISABLE

If a mobile is lost or stolen or is being used to interfere with communication, it can be temporarily or permanently disabled by the system operator.

A mobile can be temporarily disabled by transmitting the Sleep command to the unique ID of the affected mobile. When this transceiver receives this command, SLEEPNG is displayed continuously and no calls can be received or transmitted. However, registration on new localities continues normally. The transceiver can be re-enabled again by sending an Interrogate message. When this message is received, the display and transceiver operation return to normal.

A mobile can be permanently disabled by sending the Kill command to the unique ID of the affected mobile. The transceiver then responds that it has received this message and then permanently disables itself. It must then be brought back in for reprogramming to make it operational again. This mode is indicated by this transceiver when CALLSVC is displayed continuously.

2.10.6 HOME CHANNEL ALIASING

Introduction

The home channel aliasing feature increases the number of standard group calls programmable on a locality. It does this by allowing calls to be programmed on non-existent home repeaters. Therefore, instead of being limited to just the 239 ID codes on each active home repeater, group calls can be programmed on each of the 20 home repeaters allowed per locality. This permits up to 20 x 239 or 4780 group calls on each locality. However, the twentieth repeater is usually the status repeater and typically not assigned as a home repeater (see following).

The active repeaters on each locality are designated by system programming (see Tables 3-2 to 3-4 in Section 3). Active repeaters are programmed with a channel number and inactive repeaters have a channel number of "0". If repeaters are later added, they can be added to the system by over-the-air programming (see Section 2.10.4).

NOTE: Since this feature does not increase system capacity, adding too many users may result in unsatisfactory operation due to frequent busy conditions.

Operation With Home Channel Aliasing

If a system programmed with a non-existent home repeater is selected, the next lower active home

repeater is monitored for incoming calls and go-to repeater information. For example, if home repeater 6 is programmed on the selected system and the active repeaters are 1, 10, and 20, repeater 1 is monitored. In addition, all other mobiles on that locality with a selected system programmed for home repeaters 1-9 monitor that repeater.

If a group call is then placed, the home channel of the call is the home channel programmed for the selected system, not the repeater being monitored. The call is detected like any other group call (it is received if a system/group programmed for that home repeater/group ID is selected or scanned).

Repeater Number Programming With Aliasing

Since the next lower numbered repeater is monitored when a system with a non-existent home repeater is selected, a numbering scheme should be used that equalizes, as much as possible, the gaps between the active repeaters. This equalizes the loading on the active channels.

When repeater 1 is reached, wrap-around to repeater 20 occurs. Therefore, the status repeater is always assigned as Repeater 20 and Repeater 1 as an active repeater. This prevents the status repeater from being used as a home repeater which is not desirable because it then has no backup repeater (see Section 4.6). The following are examples of repeater numbering schemes that should be used:

No. of Repeaters	Numbering
1	20
2	1, 20
3	1, 10, 20
4	1, 7, 14, 20
5	1, 5, 10, 15, 20
10	1, 3, 5, 7, 9, 11, 13, 15, 17, 20

2.11 LTR FEATURES

2.11.1 GENERAL LTR FEATURES

LTR operation is described in Section 2.3.5. The two types of calls that can be placed with LTR operation are standard group and telephone. Standard group calls and other common LTR-Net and LTR features are described in Section 2.9. LTR telephone calls and

other unique LTR features are described in the information which follows.



2.11.2 LTR TELEPHONE CALLS

General

To place and receive LTR telephone calls, a block of ID codes is reserved on the locality (site) for RIC (repeater interconnect) calls. Then to place and receive LTR telephone calls on those localities, the selectable system must be programmed with this block of ID codes, and one of the selectable groups must be programmed with an ID code from this block. The transceiver then enters the telephone operating mode when that group is selected or a call is received on that ID.

To place an LTR telephone call, a telephone group must be selected. To receive an LTR telephone call, the telephone ID must be selected or scanned or be a fixed priority or block decode ID. Only telephone keypad models can be used to place telephone calls. Since operation is half-duplex, the mobile user cannot hear the landside party while transmitting or talk to the landside party while receiving.

Placing an LTR Telephone Call

1. Select the telephone system and group. When a group programmed for telephone calls is selected, the base portion  of the telephone symbol is displayed.
2. If you want to use the phone mode to place the call, select it by pressing FCN and then the PHON or SND key. The phone mode is selected when the handset portion  of the telephone symbol is displayed. Refer to Section 2.7 for more phone mode information.
3. Briefly press the PTT (push-to-talk) switch to obtain a dial tone. The proceed, busy, or intercept tone may also sound (see Section 2.3.7).
4. If using the Phone Mode, transmit the telephone number by pressing the SND key. If not using the Phone Mode, press the PTT switch and dial the number. If too much time elapses between digits, the call is automatically terminated.

5. Release the PTT switch (if applicable). When the person answers, press the PTT switch to talk and release it to listen. Since the communication path is one way at a time, you cannot hear the other person when the PTT switch is pressed or talk to the other person when it is released.
6. When the call is finished, it should be terminated by transmitting the # character (* # may also be used as described in Section 2.7.5). Three beeps indicate that the call has been terminated.

Receiving an LTR Telephone Call

1. Select or scan the group programmed for telephone calls. When a group programmed for telephone calls is selected, the base portion  of the telephone symbol is displayed.
2. When “ringing” is heard, press the PTT switch and respond. The PTT switch must be pressed to talk and released to listen as with a standard group call.
3. When the call is complete, it should be terminated as in step 6 of the preceding section.

Placing an LTR Landside-Originate Telephone Call

Calls can also be placed from a landside telephone to a mobile (if the transceiver and radio system have this capability). With most LTR systems, a mobile user can be called directly (each has a unique telephone number). With others, the mobile being called must be specified as follows:

1. Dial the number of the radio system in which the mobile transceiver is operating.
2. When the system answers, a short tone sounds to indicate that the number of the mobile being called should be dialed. This number is usually five digits long and it must be dialed using a tone-type telephone. The first two digits are the home repeater number of the mobile, and the last three digits are a telephone group ID code of that mobile.

This ID code must be one that is reserved for telephone calls. With LTR interconnect equipment, the first digit must be dialed within 5 seconds of hearing

the tone, and no more than 5 seconds must elapse between digits or the call is terminated.

3. Ringing is then heard by the landside caller while the mobile is being rung.

2.11.3 FREE SYSTEM RINGBACK, SYSTEM SEARCH, AND TRANSPOND

The LTR Free System Ringback, System Search, and Transpond features are not available with this transceiver.

2.12 CONVENTIONAL FEATURES

2.12.1 MONITOR MODE

The monitor mode disables Call Guard squelch control (if programmed) so that all activity on a selected channel (group) can be monitored. To select the monitor mode, press the AUX switch on the side. Pressing this switch toggles the monitor mode on and off. When the monitor mode is enabled,  is indicated in the top part of the display.

A conventional system must be selected to enable the monitor mode. If the AUX switch is pressed with an LTR-Net or LTR system selected and scanning occurring (“IN SCAN” displayed), scanning halts briefly and the selected system/group is displayed. Otherwise, this switch is non-functional in these modes. Refer to Section 2.3.5 for more information on channel monitoring.

2.12.2 TRANSMIT DISABLE ON BUSY

The Transmit Disable On Busy feature disables the transmitter if the channel is busy (carrier present) and no Call Guard signal or an incorrect Call Guard signal is detected when the PTT switch is pressed. If a correct Call Guard signal is detected, transmitting is permitted.

The transceiver remains in the receive mode and the monitor mode is enabled for as long as the push-to-talk switch remains pressed (no tone or message is displayed). This allows any activity on the channel can then be monitored. To key the transmitter when it is disabled by this feature, release and then press the push-to-talk switch again within 1 second.

This is a radio feature that is enabled or disabled by on all conventional groups (channels) by programming. If this feature is disabled or the monitor mode is enabled (see preceding section), transmitting is permitted even if a carrier is present on the channel.

2.12.3 RECEIVE-ONLY GROUPS

Transmitting can be disabled on each conventional group. This allows certain channels to be monitor-only. If the push-to-talk switch is pressed with a receive-only channel selected, the transmitter does not key, the intercept tone sounds, and “TX DSBL” is displayed.

2.12.4 TALK-AROUND GROUPS

Normally, all transmissions go through a repeater. However, there may be times when a mobile is out of range of the repeater system and is unable to talk to anyone even though the mobile being called is only a short distance away. In this situation, the repeater talk-around feature can be used to transmit on the receive frequency so that the transmission does not have to go through a repeater.

Any conventional group can be programmed for talk-around and it is then enabled by selecting one of those groups. It cannot be enabled or disabled by the user, and there is no indication that it is selected. This feature is not available with LTR-Net and LTR operation.

2.12.5 CALL GUARD SQUELCH

NOTE: External decoders are not supported by this transceiver.

Introduction

Tone, digital, or inverted digital Call Guard squelch can be programmed on each transmit and receive channel in any order desired. There is also an option to transmit a reverse burst or turn-off code on transmit channels programmed with Call Guard squelch. The reverse burst and turn-off code are always detected on receive channels programmed with Call Guard squelch.

The Call Guard squelch feature eliminates distracting messages intended for others using the channel. This is done by using a subaudible tone or digital code to control the squelch. This tone or code is unique to a user or a group on that channel. This tone or code is transmitted with the voice signal but is not heard because it is in the sub-audible range and is attenuated by a filter. Call Guard squelch must be used in both the transmitting and receiving transceiver to be functional.

Tone Call Guard Squelch

Tone-type Call Guard squelch utilizes subaudible tones from 67-250.3 Hz. Although there are 38 tones assigned, the top five are normally not used because of their close proximity to the voice band which starts at 300 Hz. A reverse burst can be transmitted when the push-to-talk switch is released to eliminate the squelch tail (noise burst) in the receiving transceiver. However, both the transmitting and receiving transceiver must be equipped with this feature for it to be utilized. The reverse burst is a 180-degree phase reversal for a period of time determined by the tone frequency.

Digital Call Guard Squelch

Digital Call Guard squelch uses digital data instead of subaudible tones to control the squelch. This data consists of continuous repetitions of 23-bit words. No bit or word synchronization information is used. When the push-to-talk switch is released, a turn-off code is transmitted which eliminates the squelch tail similar to the reverse burst.

Although there are 512 possible code combinations with 9 bits, only 83 are unique with the data scheme used. The number specified when the code is programmed is actually a seed for a special algorithm used to generate the 23-bit data word. The data is transmitted at a rate of 134.4 bits per second. Therefore, approximately six words are transmitted each second. When the data is decoded, 23-bit samples are taken and then the bits are rotated to determine if a valid code was received.

Digital Call Guard squelch can be programmed as normal or inverted. The only difference is that the wave-form is inverted when "IDCG" is selected. The inverted type may need to be programmed if the signal

is inverted by the repeater or another transceiver. If digital Call Guard squelch does not function, try changing to the other type.

2.12.6 PRIORITY GROUP SAMPLING

Priority group sampling is not available with this transceiver.

2.13 SUPERVISORY TONES

2.13.1 GENERAL TONES

There are several supervisory tones that are heard at various times when operating the transceiver. These tones are as follows:

Busy Tone - This tone is similar to the standard telephone busy tone, and consists of a 697 Hz tone switched on for 250 milliseconds and off for 250 milliseconds. It sounds only with LTR-Net and LTR operation when a busy condition is detected ("BUSY" is also displayed). Once a busy condition is indicated, no more access attempts are made until the push-to-talk switch is released and then pressed again.

Intercept Tone - This is a siren-like tone (alternating high and low tones) consisting of 1209 Hz and 1864 Hz tones alternating at 250 millisecond rate. This tone indicates the following error conditions:

- When this tone sounds when attempting to access the system and "NO ACCS" appears in the display, the data handshake with the repeater could not be completed. The usual cause of this is an out-of-range condition. Six access attempts are made before this tone sounds. Once it sounds, no more access attempts are made until the push-to-talk switch is released and then pressed again. Out-of-range conditions are not indicated on conventional systems.
- If this tone sounds after the transmitter has been on for an extended period and "TX TIME" appears in the display, the transmitter has been disabled by the Time-Out Timer feature (see Section 2.4.10).
- If this tone sounds as soon as the push-to-talk switch is pressed and "TX DSBL" appears in the display, a

channel is selected in the conventional mode that is programmed as receive-only (see Section 2.12.3).

Proceed (Clear-To-Talk) Tone - If enabled by the menu mode, the proceed tone sounds with LTR-Net and LTR operation after the push-to-talk switch is pressed to indicate when talking can begin (see Section 2.9.4). The “ITN” proceed tone is a 60 millisecond burst of a 697 Hz tone, and the “2TN” (loud) proceed tone is a 30 millisecond burst of the 697 Hz tone followed by a 30 millisecond burst of a 2470 Hz tone.

Key Press Tone - This is a 50 millisecond burst of the 697 Hz tone that sounds when a key is pressed. This tone can be enabled and disabled by the menu mode (see Section 2.4.7).

Low-Battery Tone - This is a 50 millisecond burst of the 1336 Hz tone that sounds when the battery needs recharging (see Section 2.4.8).

Programming Tones - There are tones which sound when a transceiver is programmed to indicate whether or not proper programming occurred.

2.13.2 LTR-NET SPECIAL CALL TONES

NOTE: The following tones are produced by the LTR-Net switch and are heard only when placing special calls.

Confirmation Tone - A short tone which sounds when the number just dialed is accepted by the system.

Call Proceed Tone - With LTR-Net Directed Group calls, ringing does not occur after the number is dialed. Instead, this short tone sounds after the confirmation tone to indicate that the audio path is complete and speaking can begin.

End Call Tone - Three beeps which sound when the end of the call has been detected by the system.

Proceed Dialing Tone - When placing a landside-originate call to a mobile, the caller may dial the number of the system and then when the system answers, a number specifying the mobile being called. This tone sounds to indicate when the number of the mobile should be entered (see Section 2.10.1).

2.13.3 LTR TELEPHONE CALL TONES

NOTE: The following tones are produced by the LTR RIC interconnect equipment and are heard only when placing LTR telephone calls.

Reorder Tone - Three beeps which indicate that the call has been terminated by the system.

Return Time Warning Tone - Two beeps which warn that you have not transmitted for an extended period. If you do not transmit within 5 seconds, the call is automatically terminated by the system. The time between transmissions is one of the parameters used by the system to detect the end of a call when the # character is not sent.

Conversation Time-Out Tone - Calls are limited to a certain length by the system. Thirty seconds before this time is reached, a “tick” begins sounding each second. When the 30-second time expires, the call is automatically terminated by the system.

Turn-Around Tone - This is a single beep which may be used to indicate to the landside party when to respond to your transmission. It sounds when you release the PTT switch, and you may partially hear this tone.

Proceed Tone - This tone consists of two beeps and it tells the landside caller when to enter the five-digit number specifying the mobile being called. Dialing of this number must be started within 5 seconds of hearing this tone, and a tone-type telephone must be used.

2.14 DISPLAY MESSAGES

Various messages appear in the seven-character alphanumeric display to indicate operating modes and error conditions. The messages that may be displayed are as follows:

All Segments On - All icons and “PROG CH” can be enabled by turning power on with the FCN switch pressed.

BUSY - Indicates that all repeaters are busy when an LTR-Net or LTR system is selected (see Section 2.9.4).

CALLSVC - Indicates that the transceiver has been disabled by an over-the-air message (see Section 2.10.5).

FCN - Indicates that the alternate function of the front panel keys has been enabled by the FCN switch on the side.

IN SCAN - With an LTR or conventional system selected, indicates that system scanning is occurring (see Section 2.8).

KP_LOCK - Indicates that the keypad has been locked (see Section 2.4.6).

LOCKED - When programming a quick select switch position, indicates that the position is locked (see Section 2.5).

Menu Mode Messages - The following messages are displayed when the menu mode described in Section 2.6 is selected:

HIPOWER - High power

LOPOWER - Low power

KP_LOCK - Keypad disabled

KP_ENAB - Normal operation

KP_MUTE - Key press tone disabled

PTT_0TN - Proceed tone disabled

PTT_1TN - Single (soft) proceed tone

PTT_2TN - Dual (loud) proceed tone

NO ACCS - Indicates that the LTR-Net or LTR repeater system could not be accessed. Refer to inter-cept tone description in Section 2.13 for more information.

PRG ERR - Indicates that an error occurred while programming the transceiver (see Section 3.4).

PROG CH - Indicates that an over-the-air update of locality channels is in progress (see Section 2.10.4).

PROGRAM - Indicates that the transceiver is in the programming mode (see Section 3.4).

RX PRI1 - Indicates that a call has been received on the first priority ID code (see Section 2.9.1).

RX PRI2 - Indicates that a call has been received on the second priority ID code (see Section 2.9.1).

SLEEPNG - Indicates that the transceiver has been temporarily disabled by an over-the-air message (see Section 2.10.5).

SJ xxx - The software version number can be displayed by pressing FNC *. The last three digits are the version number.

SYN ERR - Indicates that the frequency synthesizer is out of lock.

TX DSBL - Indicates that a receive-only channel is selected in the conventional mode, so transmitting is not allowed (see Section 2.12.3).

TX INHB - Indicates that the selected group has been detected as busy by the LTR-Net or LTR transmit inhibit feature (see Section 2.9.5).

TX TIME - Indicates the transmitter has been disabled by the Time-Out Timer (see Section 2.4.10).

2.15 TEST MODE

The transceiver has a test mode that is selected by turning power on with the TxD and RxD pins (3 and 4 respectively) of the accessory connector shorted together. To reselect the normal mode again, turn power on without these pins shorted together.

When the test mode is initially selected, the software number is displayed in the alphanumeric display until either the SYS or GRP key is pressed. The currently selected system/group is then displayed as Sxx Gxx until power is turned off. The software version number can also be displayed by pressing FNC * (keypad models only).

If all segments of the display are on, it indicates that the transceiver has not been programmed (the transceiver must be programmed to select the test mode). The transceiver operates as follows when the test mode is selected:

Channel Select - The 10 preprogrammed test channels are selected by the A/D key (standard model) or the SYS key (telephone keypad model). The test channels

are programmed by the programmer. If no changes are made to the default test channels, the channels shown in Tables 2-1 or 2-1 are programmed.

Table 2-1 800 MHz Default Test Channels

System	Channel	System	Channel
1	1	7	420
2	120	8	480
3	180	9	540
4	240	10	600
5	300	11-14	Not Selectable
6	360		

Table 2-2 900 MHz Default Test Channels

System	Channel	System	Channel
1	1	7	329
2	79	8	379
3	129	9	429
4	179	10	479
5	229	11-14	Not Selectable
6	279		

Modulation Select Key - The Group selects the following modulation schemes. The group select key is MENU (standard model) or GRP (telephone model).

Group 1: 134 Hz square wave; data filter bypassed. (Used to set modulation balance.)

Group 2: 134 Hz square wave; data filter utilized. (Used to set deviation.)

Group 3: No modulation other than from microphone.

Groups 4-10: Not used in test mode.

Transmitter Keying - The PTT switch operates normally to key the transmitter. The accessory connector PTT line is also active.

Talk-Around - The SCAN key toggles the talk-around mode ( in display indicates the talk-around mode).

Microphone Mute - The Auxiliary switch toggles microphone audio (even in the transmit mode). The mute indicator is  in the display.

Power Output - FCN toggles power output in the receive or transmit mode. Low power is indicated by “L” in the display (even in the transmit mode).

DTMF Keypad - The 0-9, #, and * keys transmit their respective tone when pressed. The microphone audio is muted when a tone is being sent.

The following conditions are also present in the test mode:

- Receiver squelch is always controlled by the carrier. The green busy indicator lights when a carrier is detected.
- Pressing FCN while turning power on enables all segments of the LCD display. Releasing FCN returns the display to normal operation. Pressing any key turns the backlight on for 3 seconds.
- If a low-battery condition occurs, the amber LED turns on and low transmit power is selected. Transmit power can be toggled back to high using FCN. However, low power is again selected when a low battery is detected. If a low battery is detected while transmitting, low power is not selected until the PTT switch is released.

SECTION 3 TRANSCEIVER PROGRAMMING

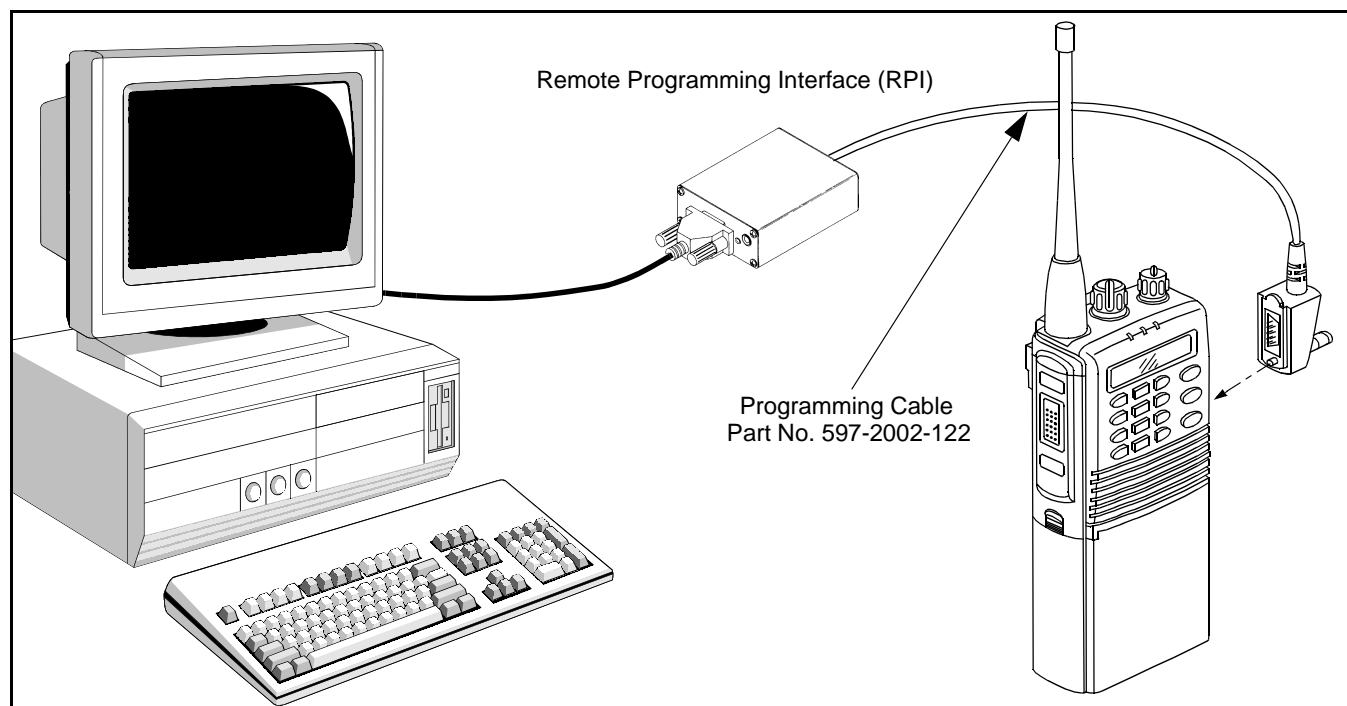

Figure 3-1 Programming Setup

3.1 GENERAL

3.1.1 PROGRAMMING SETUP

The following items are required to program this transceiver. The part numbers of the RPI, cables, and software are shown in Table 1-1 in Section 1. The programming setup is shown above.

- IBM® PC or compatible personal computer
- EFJohnson Remote Programming Interface (RPI) and interface cables
- EFJohnson 8170 LTR-Net programming software

3.1.2 COMPUTER DESCRIPTION

The transceiver programming software is MS-DOS® based program designed to run on a computer that meets the following minimum requirements:

- 640K RAM
- MS-DOS® Version 3.0 or higher
- A 3½" (high density) floppy disk drive
- A second 3½" drive or a hard disk drive
- An unused serial port

The program ships on a 3½" 1.44 MB floppy disk, and extracts into several files that require a total of approximately 415K of disk space. The program uses color to highlight various types of information on the screen, but a monochrome monitor also provides satisfactory operation. Most video formats are supported.

3.1.3 REMOTE PROGRAMMING INTERFACE (RPI)

The RPI provides the required electrical interface between the computer and transceiver. It converts the RS-232 logic levels of the computer to the TTL levels of the transceiver and vice versa. Various RPIs can be used to program this transceiver including Part Nos. 023-5810-000, 023-9750-000, and 023-9800-000.

The switch on the RPI is used to turn power of a remote-mount mobile transceiver on and off, and may also select the Flash programming mode with some transceivers. With this transceiver, it should be in the position that lights the indicator green when power is applied to the transceiver and RPI.

The cable between the RPI and computer is not included with the RPI. The 5810 and 9750 RPIs have a female DB-25 connector, and the 9800 RPI has a female DB-9 connector. Most computers have a male DB-9 or DB-25 connector. Therefore, a cable with a male DB-9 or DB-25 connector on one end and a female DB-9 or DB-25 connector on the other end is usually required. The cable from the RPI to the transceiver is also not included. The required cable is Part No. 597-2002-122. Available cables are listed in Table 1-1 in Section 1.

3.1.4 EEPROM DATA STORAGE

The data programmed into the transceiver is stored by an Electrically Erasable Programmable Memory (EEPROM) on the transceiver logic board (IC304). Since this type of memory is nonvolatile, data is stored indefinitely without the need for a constant power supply. Therefore, the battery can be removed from the transceiver and it can even be stored indefinitely on a shelf without affecting programming.

3.1.5 SOFTWARE DESCRIPTION

The 8170 programming software programs LTR-Net 8170 series transceivers only. It cannot be used to program the Avenger SI/SK (815x/816x) versions of this transceiver or other transceivers.

This is a DOS program, so Windows® 3.1/95/NT is not required. However, it can probably be run using one of these operating systems if desired. If the program does not run correctly in Windows, restart in the DOS mode in Windows 95/NT, or exit Windows and run from the DOS prompt (such as C:\>) in Windows 3.1.

3.1.6 SOFTWARE INSTALLATION

When you receive the programming software, make a backup copy and store the master disk in a safe place. To make a copy of the distribution disk, use the DOS copy command. For example, to copy all the files on the disk in drive A: to the disk in drive B:, type COPY A:.* B:.

If you have a hard disk drive, you may want to create a separate directory for programming. For example, to create a directory called RADIOPRG on

drive C:, type C: to make it the current drive and then MD \RADIOPRG (press ENTER after each command). Then to change to that directory so that it is the current directory, type CD \RADIOPRG.

The programming software is a self extracting file called TRUNK2.EXE on a 3½” high density (1.44 MB) diskette. This file unpacks into the following files:

Filename	Approx. Size
LTRNETPG.EXE	403K
CGINFO.WIN	3K
MHZ.WIN	2K
SYSINFO.WIN	4K
HELP.TXT	4K

To extract these files so that the program can be used, first make the current directory the destination directory for these files. For example, to make it the \RADIOPRG directory on drive C: (if it is not the current directory), type C: (Return) and then CD \RADIOPRG as just described. To make it the disk in drive B:, simply type B:. Then insert the program disk in drive A: and type A:TRUNK2 (or B:TRUNK2 if drive B: is being used). The program files are automatically extracted into the current directory or disk.

3.1.7 CONNECTING PROGRAMMING SETUP

Connect the programming setup as shown in Figure 3-1. It is recommended that both computer and transceiver power be off when this is done. The RPI is connected to an unused serial port of the computer using one of the cables described in Section 3.1.3.

The RPI-to-transceiver cable is Part No. 597-2002-122, and it connects to the accessory jack on the side of the transceiver. After the RPI is connected, turn transceiver power on. The green indicator on the RPI should light to indicate that power is applied to the RPI. If this indicator is amber, move the switch on the RPI to the other position.

The first time the program is run on a computer, the serial port may have to be selected. The program defaults to serial port 1 (COM1:). If some other serial port is used, it must be selected as described in Section 3.2.7 to establish communication with the radio.



Figure 3-2 Main Menu Bar

3.1.8 STARTING PROGRAM

Start your computer as described in the information included with your computer. Once this has been done and the DOS prompt appears, type LTRNETPG (the current directory should be the directory containing the program and other files). On-screen prompts then instruct you how to proceed.

3.1.9 OPERATION WITH LCD SCREENS

With some computers (such as those with LCD screens), information on the screen may be difficult to see if the color mode is selected. Normally, the video mode and other configuration information is specified in SETUP screen of the program (see Section 3.2.7). This information is then automatically saved to a file called TRUNKING.CFG and it is used by the program to set the configuration the next time it is run.

However, the first time the program is run, default conditions are used. If you are unable to read the screen, the monochrome mode can be selected from the command line by entering /L after LTRNETPG (LTRNETPG/L).

3.2 MAIN MENU PARAMETERS

3.2.1 INTRODUCTION

When the opening screen is displayed, press any key to go to the Main Menu Bar shown in Figure 3-2. Various screens can then be selected using this menu bar. Use the arrow keys to highlight the desired menu (mouse operation is not supported) and then select it by pressing Enter. Help menus can be displayed by pressing F1. Error or warning messages are displayed if a parameter is entered that is not within the allowed limits.

When the program starts, the file LTRNETPG.DAT is always loaded. This file contains the parameters that were selected the last time the

program was run. Information is written to this file when the program is exited by selecting QUIT.

NOTE: To save the current configuration to a disk file so that it can be recalled, use the FILES menu "Write Configuration To File" function (see Section 3.2.6).

To display a DOS shell, select "Temporary Exit To DOS" in the FILES menu (see Section 3.2.6). This allows DOS commands to be executed without exiting the program. Type "EXIT" to return to the program. The following information describes the screens that are selected from the main menu.

3.2.2 SELECT MENU

The Select menu shown below is used to select the transceiver to be programmed. Move the highlight bar to "817x 3-Key" (standard model) or "817x 15-key" (telephone keypad model), whichever is being programmed and then press Enter.

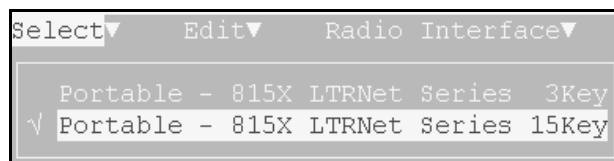

3.2.3 EDIT MENU

The EDIT menu which follows is used to enter the various types of programming data. The parameters in this menu are as follows:

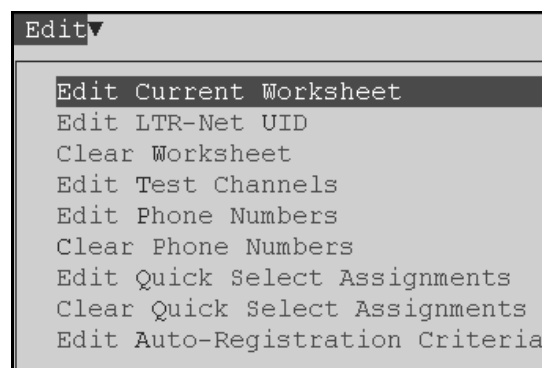

Edit/Clear Current Worksheet

Selecting “Edit Current Worksheet” displays the Radio Parameter screen shown in Table 3-1. The parameters entered in the last programming session are displayed in this screen (see Section 3.2.1). If you want to display this screen with no systems programmed and default values for the radio parameters, select “Clear Worksheet” first.

This screen is also used to create new systems or select systems to be edited. Press the F3 key to move the cursor to the system portion of the screen and then highlight the system to be edited and press the Enter key. When a “Not Used” system is selected, the following screen is displayed to create a new system. If F2 is pressed with a system selected, this screen is displayed to change the system type.

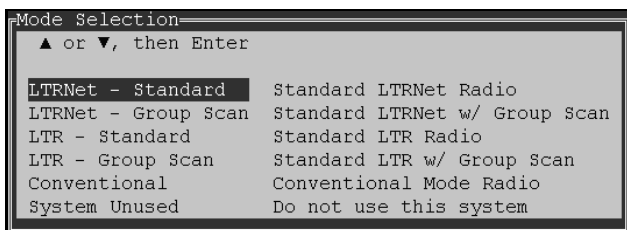

The Radio Parameters screen and descriptions of the parameters it programs are located in the table listed below. In addition, the LTR-Net, LTR, or conventional system screens which are displayed from this screen and descriptions of the parameters in each are located in the tables listed below.

Radio Parameters	Table 3-1
LTR-Net Systems	Table 3-2
LTR Systems	Table 3-3
Conventional Systems	Table 3-4

Edit LTR-Net UID

This screen follows and is used to edit the unique ID code and alpha tag that are programmed for each system. This screen allows this information to be edited without having to individually display the screen for each system.

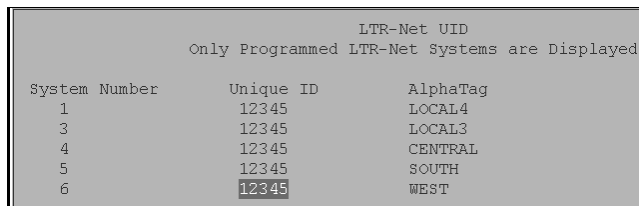

Edit LTR-Net UID Screen

Edit Test Channels

When the data is programmed into the transceiver, ten test channels are also programmed for use in the test mode. Default test channels are automatically programmed unless they are changed using the “Edit Test Channels” screen (the 800 MHz version is shown below). Refer to Section 2.15 for more information on the test mode.

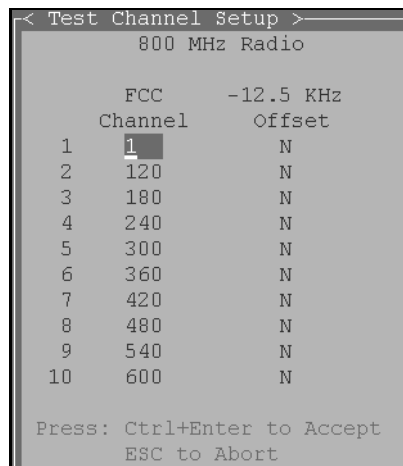

Edit/Clear Phone Numbers

This screen follows and is used to program the six telephone numbers that can be recalled from memory in the Phone Mode. If “Write Protect = Y”, the number cannot be reprogrammed by the user. Refer to Section 2.7.4 for more information on programming these numbers.

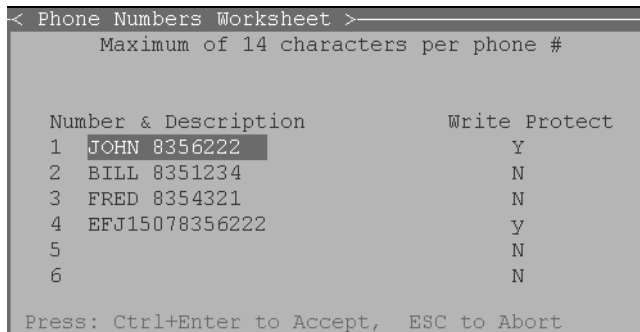

Edit/Clear Quick Select Assignments

This screen follows and is used to program the system/group selected by each quick select switch position. If the transceiver has a telephone keypad, these positions can be reprogrammed by the user if "Lock = N". Refer to Section 2.5 for more information.

Pos.	System	Group	Lock
1.	1	1	Y
2.	1	2	Y
3.	1	3	Y
4.	2	1	Y
5.	2	2	N
6.	2	3	N
7.	3	1	N
8.	3	2	N
9.	3	3	N
10.	4	1	N
11.	4	2	N
12.	4	3	N
13.	3	4	N
14.	3	6	N
15.	4	4	N
16.	4	6	N

Press: Ctrl+Enter to Accept, ESC to Abort

Edit Auto-Registration Criteria

This screen follows and is used to program the Dropout Criteria and Capture (Pickup) Criteria on each system. This screen allows this information to be edited without having to individually display the screen for each system.

Dropout Criteria sets the percentage of good data messages that must be detected to stay on the current site, and Capture Criteria sets the percentage of good data messages that must be detected to attempt registration on a new site. Refer to Section 2.10.3 for more information.

System Number	Locality ID	Dropout (50-90%)	Pickup (50-90%)
1	4	75	80
3	3	75	75
4	100	75	80
5	101	75	80
6	102	75	80

Ctrl+Enter to Accept, ESC to Abort

3.2.4 RADIO INTERFACE MENU

Radio Interface
Prompted - Write Configuration to Radio/Unit
Fast - Write Configuration to Radio/Unit
Read Configuration from Radio/Unit

The Radio Interface menu shown above is used to initiate the actual downloading of data to the transceiver and also read (upload) data from a transceiver. When Fast Write is selected, some prompts are not shown and writing begins immediately. This menu is selected when all required information has been entered in the Edit Worksheet screen and is ready to send to the transceiver. It is also selected to read the information programmed in a transceiver including the ESN (see Table 3-1).

3.2.5 SYSTEM MENU

System
Copy a System From this Radio/Unit
Read a System From a Stored File
Print a System Configuration
Print a System Configuration to File
Delete a System

The System menu shown above is used to copy, read, print, or delete a system configuration as follows:

Copy a System - An existing system is copied to another system. For example, the data in System 2 can be copied to System 5. The information in that system can then be edited. This allows similar systems to be set up without having to re-enter all the data.

Read a System From a Stored File - A system stored in a disk file is copied to a current system. A directory listing can be displayed if desired by pressing F2 after this function is selected.

Print a System - Prints the data programmed in the specified system. If you want to print the entire configuration including radio parameters and all system/groups, use the Files menu described in the next section.

Delete a System - Deletes data in the specified system and returns it to the "Not Used" status.

3.2.6 FILES MENU

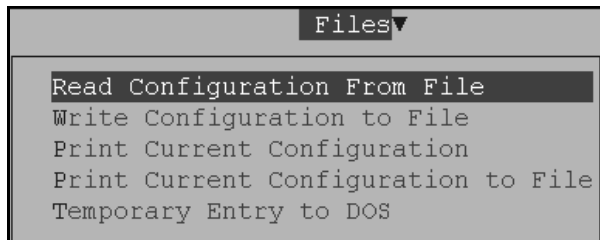

The Files menu shown above is used to read, write, or print a configuration file as follows. It is also used to temporarily open a DOS shell. These functions operate as follows:

Read Configuration - Copies all the configuration data from a disk file. This can be used to duplicate an existing file so that it can be edited. A directory listing can be displayed by pressing F2 after this function is selected. A different directory can be specified if desired.

Write Configuration - Saves the current configuration information to a disk file. The program prompts for a file name. Up to eight characters and a three-character extension can be entered (xxxxxxx.xxx). A directory listing can be displayed by pressing F2. A different directory can be specified if desired. This operation must be performed if you want to recall the file for use at a later date. The current parameters are also saved to a file called LTRNETPG.DAT (see Section 3.2.1).

Print Current Configuration - Prints the current configuration information to a printer or disk file. Configuration information for a single system can be printed using the System menu "Print a System" function described in the preceding section.

Temporary Entry to DOS - Displays the DOS command line without having to exit the program. This allows DOS commands to be executed such as file copies, directory listings, and disk formatting. To return to the program, type EXIT.

3.2.7 SETUP MENU



The SETUP menu shown above is used to select the serial port, display prompts, and video mode. Information selected in this menu is stored in a file called TRUNKING.CFG that is automatically loaded the next time the program is run.

COM Port - This selects the serial port that is used by the RPI. If the mouse is connected to COM1:, you may want to use COM2: for the RPI. The serial port may also be specified on the command line when the program is run by typing /C1 (for COM1:) or /C2 (for COM2:) after LTRNETPG.

Display Prompts - This turns the display prompts on and off. These are prompts that request certain actions be confirmed before they are executed such as when exiting a level or the program. Prompts can also be turned off on the command line by typing /N after LTRNETPG.

Color or Monochrome Display - Selects either the color or monochrome video mode. Some lap top computers may not display information properly unless the monochrome mode is selected. To select the monochrome video mode from the command line, type /L after LTRNETPG (see Section 3.1.9 for more information).

3.3 MISCELLANEOUS INFORMATION

3.3.1 REPEATER NUMBER PROGRAMMING

With LTR-Net and LTR repeaters, the repeaters at a locality (site) are assigned a unique number from 1-20. Although these numbers can be assigned arbitrarily, for maximum system efficiency, a scheme should be used which equalizes, as much as possible, the gaps between numbers. For example, a five-repeater system should be numbered 1, 5, 10, 15, and 20. These numbers are programmed in the repeater and also each mobile system.

If Home Channel Aliasing is used, the status repeater should be repeater 20 and repeater 1 should be an active repeater. The other repeaters should then be spaced evenly from 1-20 (see Section 2.10.6).

3.3.2 CHANNEL NUMBER PROGRAMMING

NOTE: Use the programming channel numbers, not the FCC channel numbers to program this transceiver.

The channel numbers used to program this transceiver come from the channel tables at the end of this section. The 800 MHz channels from 1-600 are the same as the FCC channels. However, for channels above 600, a special programming channel number is used because some channels were skipped by the FCC scheme. For channels 1-600, a 12.5 kHz offset band can be selected for operation near certain U.S. border areas. This offset does not apply to the other channels because they have a 12.5 kHz spacing.

3.3.3 SPECIFYING RIC-EQUIPPED REPEATERS (LTR ONLY)

When programming the channel numbers of LTR systems, you can specify if the repeater is equipped with an EFJohnson repeater interconnect (RIC/TIC) controller. If a system with a transmit ID code programmed for interconnect is then selected, the transceiver will attempt to access only repeaters specified as equipped with this controller. This allows both interconnect and non-interconnect repeaters to be programmed in each system.

Without this feature, the transceiver may trunk to a repeater not equipped with an interconnect controller when a telephone call is made. No dial tone or other supervision is then returned when the PTT switch is released which may be confusing to the user.

3.4 PROGRAMMING ERRORS

When proper transceiver programming has occurred, a steady 697 Hz tone sounds. However, if an error occurs while programming is taking place, a busy tone sounds and PRG ERR is displayed. The two types of errors that may be indicated are as follows:

EEPROM Error - If an error is detected when the data written to the EEPROM is checked,  is displayed. Try repeating the programming procedure. If an error occurs again, the EEPROM is probably defective.

Communications Error - If the communications path is interrupted while programming is occurring, checksum information in the data indicates an error. This error is indicated by the green Busy indicator. Check the programming setup cables and repeat the programming procedure.

3.5 CLONING

With LTR-Net models of this transceiver, one transceiver cannot be used to program another. This is due to the use of ESNs (Electronic Serial Numbers) and unique ID codes which must be different from transceiver to transceiver.

Table 3-1 Radio Parameters Screen

F1=Help, F3=Go to System Num, F5=Top, F6=Bottom, Ctrl+Enter=Accept, ESC=Abort		
Frequency Band 800/900MHz: 800 MHz	Phone System (1-14): 0	
Return Hang Time (1-8): 3 Sec	Phone Group (1-11): 0	
Call Delay Timer (1-8): 3 Sec	Revert(L-Last Sel/T-Temp): L	
Receive Delay Timer(1-8): 3 Sec		
Transmit Timeout : 3.0 Min	-----LTR-Net Only -----	
Home System(1-14): 1		
Home Group (1-11): 1	Double No Access Loc. Srch. (Y/N): Y	
Home Key (Last-L / Home-H) : L	ESN : 401	
Conv Tx Disable on Busy(Y/N): Y		
Aux. Button (E-Emerg/M-Mon.): M		
Arrow Keys to move and Enter to Edit system, F2 to change the mode.		
1- LTRNet LOCAL4	8- Unused	
2- LTR LTR	9- Unused	
3- LTRNet - Grp Scn LOCAL3	10- Unused	
4- LTRNet - Grp Scn CENTRAL	11- Unused	
5- LTRNet - Grp Scn SOUTH	12- Unused	
6- LTRNet - Grp Scn WEST	13- Unused	
7- Unused	14- Unused	
Notes:		
Edit Portable Radio Configuration Worksheet.		ltrnet.dat

The Radio Parameters screen shown above is selected by the Edit > Edit Current Worksheet menu. To clear this worksheet to default values, select Edit > Clear Worksheet first. This screen programs the parameters that are the same for all systems and groups. In addition, it is used to set up new systems and select systems to be edited (see Section 3.2.3).

Parameter	Acceptable Responses	Description
Frequency Band	800 or 900 MHz	8170 = 800 MHz, 8172 = 900 MHz
Return Hang Time [1]	1-7 seconds	Sets the length of time the home or last active system/group is displayed when the HOME key is pressed (Section 2.4.5).
Call Delay Timer	1-8 seconds	Sets the delay that occurs before scanning resumes after transmitting a message (Section 2.8.6).
Receive Delay Timer	1-8 seconds	Sets the delay that occurs before scanning resumes after receiving a message (see Section 2.8.6). Programming "8" seconds also selects "Last Received Revert" (Section 2.8.7).
Transmit Time-Out	0.5-5.0 minutes in 0.5 minute increments	Programs the Time-Out Timer (Section 2.4.10).
Home System/Group [1]	Any programmed system/group	Programs the system/group that is selected by the HOME key if the following Home Key parameter is programmed to select the home system/group (Section 2.4.5).
Home Key [1]	L = Last Selected H = Home	Programs the system/group that is selected when the HOME key is pressed (Section 2.4.5).
Conv Tx Disable on Busy	Yes, No	"Yes" programs the Transmit Disable On Busy feature on all conventional systems (Section 2.12.2).
Auxiliary Button	E (Not available) M = Monitor	This parameter defaults to M (monitor) and should be left in that mode. The E (emergency) function is not available with this transceiver, so the monitor function is always selected (Section 2.12.1).

Table 3-1 Radio Parameters Screen (Continued)

Parameter	Acceptable Responses	Description
Phone System/Group [1]	Any LTR-Net or LTR system/group that is programmed for telephone calls (conventional groups are not allowed)	Programs the telephone system/group that is automatically selected when the Phone Mode is enabled by pressing FCN SND (Section 2.7).
Revert (scan mode)	L = Last Selected T = Temporary	Programs which system/group is selected when the transmitter is keyed in the scan mode (Section 2.8.7). To program "Last Received", see "Receive Delay Timer" parameter above. This parameter is then ignored, so it can be either "L" or "T".
Double No Access Locality Search	Yes, No	"Yes" enables the function that automatically initiates a new locality search if two consecutive "NO ACCS" conditions occur (Section 2.14). Cycling power or a successful access resets the counter.
ESN (Electronic Serial Number)	Not applicable	When data is read from a transceiver, the ESN of the transceiver is displayed. This number cannot be changed.

[1] These parameters do not apply to the standard model (without telephone keypad).

Table 3-2 LTR-Net System Parameters

<pre> F1=Help, F3=Go to CHN, F4=Clear, F5=Top, F6=Bottom, Ctrl+Enter=Accept, ESC=Abort System: 5 Mode: LTRNet - GrAlphaTag : SOUTH Home Repeater: 1 Area: 0 UID : 12345 Status Repeater: 20 Locality: 1 Roaming Criteria - Drop out: 75 Pick Up: 80 PrefLoc#1: 6 Transmit Inhibit - Start Id: 220 Stop Id: 239 PrefLoc#2: 75 Block Decode - Start Id: 200 Stop Id: 210 PrefLoc#3: 80 Fixed Priority 1 - Id: 200 Call Light (Y/N): Y PrefLoc#4: 1 2 - Id: 201 Call Light (Y/N): N PrefLoc#5: 730 Channel Information Offset = -12.5 KHz No. CHN Ofst No. CHN Ofst No. CHN Ofst No. CHN Ofst 1 385 N 2 0 N 3 0 N 4 0 N 5 0 N 6 0 N 7 389 N 8 0 N 9 0 N 10 0 N 11 0 N 12 0 N 13 0 Y 14 395 Y 15 0 N 16 0 Y 17 0 Y 18 0 N 19 0 Y 20 399 N Group Information GR Encode Decode Call GR Encode Decode Call 1 220 220 N 2 129 129 N 3 205 205 N 4 241 241 N 5 0 0 N 6 0 0 N 7 0 0 N 8 1 0 Y 9 0 0 Y 10 20 0 Y Edit LTR System Worksheet - Press F1 for Information- Arrow Keys to Move </pre>			
--	--	--	--

The LTR-Net System screen shown above is selected from the Radio Parameters screen shown in Table 3-1. Highlight the desired LTR-Net system at the bottom or Not Used to create a new system and then press the Enter key (see Section 3.2.3). This screen programs the groups and other information unique to one of the selectable LTR-Net systems.

Parameter	Acceptable Responses	Description
Mode	LTR-Net or LTR (with or without group scan), Conventional, Unused	Identifies the type of system that is programmed. To change the system type, go to the Radio Parameters screen (see Table 3-1) and press F2 with the system highlighted. For information on group scan, refer to Section 2.8.2.
Alpha Tag (System)	Uppercase A-Z, 0-9, - + * () /	Programs the unique 7-character system identification. It is displayed by the transceiver if alpha tag display mode is selected (Section 2.3.2). Otherwise, only the system and group numbers are displayed.

Table 3-2 LTR-Net System Parameters (Continued)

Parameter	Acceptable Responses	Description
Comanding	Yes, No	Programs if companding is enabled when the system is selected (Section 2.4.3). This parameter is displayed only when the 900 MHz frequency band is selected in the Radio Parameters screen.
Home Repeater	1-20	Programs the number of the home repeater to which the transceiver is assigned (Section 3.3.1).
Area	0, 1	“0” is usually programmed unless two or more LTR-Net or LTR localities (sites) are close enough to interfere with each other. One locality is then programmed “0” and the other “1”.
UID (Unique ID)	1-65503	Programs the unique ID of the mobile (Section 4.7.1). This can also be programmed using the “Edit LTR-Net UID” screen described in Section 3.2.3.
Status Repeater	1-20	Programs the number of the status repeater (Section 3.3.1).
Locality Number	1-1023	Programs the number of the locality (site). Each locality that a mobile can access must have a different locality number, and the same scheme must be used to program the mobiles and repeaters.
Roaming Criteria, Drop out	50-100%	Programs the percentage of good data messages that must be received to stay on the current locality when roaming. The default is 75% (Section 2.10.3). This can also be programmed using the “Edit Auto-Reg. Criteria” screen described in Section 3.2.3.
Roaming Criteria, Pick Up (Capture)	50-100%	Programs the percentage of good data messages that must be received to initiate registration on new locality when searching for a new locality is occurring. The default is 80% (Section 2.10.3).
Transmit Inhibit Block	1-239	Programs the transmit inhibit block of ID codes. If a code within this block is decoded up to 5 seconds before the PTT switch is pressed, the transmitter does not key (Section 2.9.5).
Block Decode	1-239	Programs a block of ID codes that are decoded regardless of the group selected (Section 2.9.2).
Fixed Priority 1 and 2 ID Codes	1-239, 240, 241 [1]	Programs the Fixed Priority 1 and 2 decode codes if they are used (Section 2.9.1).
Call Light	Yes, No	Programs if Call indicator is enabled when a call is detected on the ID code (Section 2.4.2).
Preferred Locality 1-5	Number of a programmed locality	Programs the localities that are searched first when locality search is initiated. Preferred Locality 1 is checked first, Locality 2 second and so on. Not used localities are programmed “0” (Sect. 2.10.3).
CHANNEL INFORMATION		
Number	1-20	The active repeaters accessed by the system are assigned to numbers 1-20 (Section 3.3.1).
Channel	1-840 (800 MHz) 1-479 (900 MHz)	Programs the channel number of each active repeater (Section 3.3.2). Inactive repeater numbers are programmed “0”. Channel numbers are listed in the table at the end of this section. Use the programming channel number, not the FCC channel number.
Offset (-12.5 kHz)	Yes, No	For channels 1-600, programs if they are offset 12.5 kHz on the low side (Section 3.3.2).
GROUP INFORMATION		
Selectable Groups (1-10)	1-239, 240, 241 [1]	Programs the selectable decode (receive) and encode (transmit) IDs (Sections 2.9.3 and 2.10.1). Both IDs in a group must be programmed. With the standard model (w/o telephone keypad), only the system/groups programmed for the quick select switch (see Section 3.2.3) are transferred into the transceiver (Section 2.5).
Call (Indicator)	Yes, No	Selects if the call indicator is enabled when a call is received on the group (Section 2.4.2).
[1] 1-239 = Standard group calls, 240 = Auxiliary calls, 241 = Telephone calls (see Sections 2.9.3 and 2.10.1).		

Table 3-3 LTR System Screen Description

```

F1=Help, F3=Go to CHN, F4=Clear, F5=Top, F6=Bottom, Ctrl+Enter=Accept, ESC=Abort
System: 2           Mode: LTR           AlphaTag : LTR 1   Comp(Y/N) N
Home Repeater: 1   Area: 0           Scan Weighting : 1
Rprr Interconnect -Start Id: 190       Stop Id: 208
Transmit Inhibit - Start Id: 209       Stop Id: 240
Block Decode     - Start Id: 209       Stop Id: 240
Emergency        - System: 0           Group: 0           Auto-Tx (Y/N): N
Fixed Priority 1 - Id: 210              Call Light (Y/N): N Horn (Y/N): N
                  2 - Id: 211          Call Light (Y/N): N Horn (Y/N): N
Data Priority Grp Position : 0         (Only Used by Data Radios)
Channel Information      Offset = -12.5 KHz
No. CHN Ofst RIC       No. CHN Ofst RIC       No. CHN Ofst RIC       No. CHN Ofst RIC
1  395  N  Y           2   0  N  N           3   0  N  N           4   0  N  N
5   0  N  N           6   0  N  N           7 389  N  Y           8   0  N  N
9   0  N  N          10  0  N  N          11  0  N  N          12  0  N  N
13  0  N  N          14 393  N  Y          15  0  N  N          16  0  N  N
17  0  N  N          18  0  N  N          19  0  N  N          20 399  N  Y
Group Information
GR  Encode Decode Trnspnd Call Horn      GR  Encode Decode Trnspnd Call Horn
1   209   209     N     N     N           2   0     0     N     N     N
3   207   207     N     Y     N           4   0     0     N     N     N
5     0     0     N     N     N           6   0     0     N     N     N
7     0     0     N     N     N           8   0     0     N     N     N
9     0     0     N     N     N          10  0     0     N     N     N
Edit LTR System Worksheet - Press F1 for Information-      Arrow Keys to Move
    
```

The LTR System screen shown above is selected from the Radio Parameters screen shown in Table 3-1. Highlight the desired LTR system at the bottom to edit a system or Not Used to create a new system and then press the Enter key (see Section 3.2.3). This screen programs the groups and other information unique to one of the selectable LTR systems.

Parameter	Acceptable Responses	Description
Mode	LTR-Net or LTR (with or without group scan), Conventional, Unused	Identifies the type of system that is being programmed. To change the system type, go to the Radio Parameters screen (see Table 3-1) and press F2 with the system selected. For information on group scan, refer to Section 2.8.2.
Alpha Tag	Uppercase A-Z, 0-9, - + * () /	Programs the unique 7-character system identification. It is displayed by the transceiver if alpha tag display mode is selected (Section 2.3.2). Otherwise, only the system and group numbers are displayed.
Companding	Yes, No	Programs if companding is enabled when the system is selected (Section 2.4.3). This parameter is displayed only when the 900 MHz frequency band is selected in the Radio Parameters screen.
Home Repeater	1-20	Programs the number of the home repeater to which the transceiver is assigned (Section 3.3.1).
Area	0, 1	“0” is usually programmed unless two or more LTR-Net or LTR localities (sites) are close enough to interfere with each other. One locality is then programmed “0” and the other “1”.
Scan Weighting	Not applicable	This parameter is not used with this transceiver, so it can be left in the default condition.
Repeater Interconnect (RIC) ID Code Block	1-250 (1-239 if accessing an LTR-Net system)	Programs the block of ID codes that are used for LTR telephone calls. If an ID code within this block is detected when receiving or transmitting, the transceiver enters the telephone operating mode (Section 2.11.2).

Table 3-3 LTR System Screen Description (Continued)

Parameter	Acceptable Responses	Description
Transmit Inhibit Code Block	1-250 (1-239 if accessing an LTR-Net system)	Programs the transmit inhibit block of ID codes. If a code within this block is decoded up to 5 seconds before the PTT switch is pressed, the transmitter does not key (Section 2.9.5).
Block Decode Code Block	1-250 (1-239 if accessing an LTR-Net system)	Programs the block of ID codes that are decoded regardless of the group that is selected (Section 2.9.2).
Emergency System/Group Auto-Tx	Not applicable	The emergency switch is not available with this transceiver, so these parameters can be left in the default condition.
Fixed Priority 1 and 2 ID Codes	1-250 (1-239 if accessing an LTR-Net system)	Programs the Fixed Priority 1 and 2 decode codes if they are used (Section 2.9.1).
Call Light	Yes, No	Programs if the call indicator lights when a call is received on that ID code (Section 2.4.2).
Horn	Not applicable	This feature is not available with this transceiver, so it can be left in the default condition.
Data Priority Group	Not applicable	This feature is not available with this transceiver, so it can be left in the default condition.
CHANNEL INFORMATION		
Number	1-20	The active repeaters accessed by the system are assigned to numbers 1-20 (Section 3.3.1).
Channel	1-840 (800 MHz) 1-479 (900 MHz)	Programs the channel number of each active repeater (Section 3.3.2). Inactive repeater numbers are programmed "0". Channel numbers are listed in the table at the end of this section. Use the programming channel number, not the FCC channel number.
Offset (-12.5 kHz)	Yes, No	For channels 1-600, programs if they are offset 12.5 kHz on the low side (Section 3.3.2).
RIC	Yes, No	Programs if the repeater is equipped with RIC/TIC interconnect module (Section 3.3.3).
GROUP INFORMATION		
Selectable Groups (1-10)	1-250 (1-239 if accessing an LTR-Net system)	Programs the selectable decode (receive) and encode (transmit) IDs (Sections 2.9.3 and 2.11.2). Both IDs in a group must be programmed. With the standard model (w/o telephone keypad), only the system/groups programmed for the quick select switch (see Section 3.2.3) are transferred into the transceiver (Section 2.5).
Transpond	Not applicable	This feature is not available with this transceiver, so it can be left in the default condition.
Call (Indicator)	Yes, No	Selects if the call indicator is enabled when a call is received on the group (Section 2.4.2).
Horn	Not applicable	This feature is not available with this transceiver, so it can be left in the default condition.

Table 3-4 Conventional System Parameter Description

F1=Help, F4=Clear, F5=Top, F6=Bottom, Ctrl+Enter=Accept, ESC=Abort												
System: 7 Mode: Conventional												
AlphaTag: CONV 1 Compand (Y/N): N												
Group Information												
GR No	CHN NUM	Off-set	RX Type	CG Value	TX Type	CG Value	TX Disable	Send Turnoff	Talk-Around	Call Light	Call Horn	
1	200	N	TCG	31	TCG	31	N	Y	N	Y	N	
2	205	N	TCG	32	TCG	32	N	Y	N	Y	N	
3	0	N	NONE	0	NONE	0	N	Y	N	N	N	
4	0	N	NONE	0	NONE	0	N	Y	N	N	N	
5	0	N	NONE	0	NONE	0	N	Y	N	N	N	
6	0	N	NONE	0	NONE	0	N	Y	N	N	N	
7	0	N	NONE	0	NONE	0	N	Y	N	N	N	
8	0	N	NONE	0	NONE	0	N	Y	N	N	N	
9	0	N	NONE	0	NONE	0	N	Y	N	N	N	
10	0	N	NONE	0	NONE	0	N	Y	N	N	N	
Emergency - System : 0 Group: 0 Auto-Tx (Y/N): N												
Data Priority Grp Position: 0 (Only Used by Data Radios)												
Edit Conventional System Worksheet -Press F1 for Information- Arrow Keys to Move												

The Conventional System screen shown above is selected from the Radio Parameters screen shown in Table 3-1. Highlight the desired conventional system to edit a system or Not Used to create a new system and then press the Enter key (see Section 3.2.3). This screen programs the groups and other information unique to one of the selectable conventional systems.

Parameter	Acceptable Responses	Description
Mode	LTR-Net or LTR (with or without group scan), Conventional, Unused	Identifies the type of system that is being programmed. To change the system type, go to the Radio Parameters screen (see Table 3-1) and press F2 with the system selected. For information on group scan, refer to Section 2.8.2.
Alpha Tag	Uppercase A-Z, 0-9, - + * () /	Programs the unique 7-character system identification. It is displayed by the transceiver if alpha tag display mode is selected (Section 2.3.2). Otherwise, only the system and group numbers are displayed.
Companding	Yes, No	Programs if companding is enabled when the system is selected (Section 2.4.3). This parameter is displayed only when the 900 MHz frequency band is selected in the Radio Parameters screen.
GROUP INFORMATION		
Group No./Channel No.	Group = 1-10 Channel = 1-840 (800 MHz) = 1-479 (900 MHz)	Programs the channel number for the selectable groups being used (Section 3.3.2). Channel numbers are listed in the table at the end of this section. Use programming channels, not FCC channels. With the standard model (w/o telephone keypad), only the system/groups programmed for the quick select switch (see Section 3.2.3) are transferred into the transceiver (Section 2.5).
Offset (-12.5 kHz)	Yes, No	For channels 1-600, programs if they are offset 12.5 kHz on the low side (Section 3.3.2).

Table 3-4 Conventional System Parameter Description (Continued)

Parameter	Acceptable Responses	Description
Rx CG Type	None, TCG, DCG, IDCG	Programs the type of receive (decode) Call Guard squelch for that group (Section 2.12.5). The EXT ± configuration is not available with this transceiver.
None = Carrier, TCG = Tone (CTCSS), DCG = Digital, IDCG - Inverted digital, Ext = External decoder (not available)		
Rx CG Value	Tone number or digital code	If TCG was selected, the tone number from 1-39 is entered. If digital was selected, the digital code is entered. These numbers are listed in Table 3-5.
Tx CG Type	None, TCG, DCG, IDCG	Programs the type of encode (receive) Call Guard squelch for that group (Section 2.12.5).
Tx CG Value	Tone number or digital code	If TCG was selected, the tone number from 1-38 is entered. If digital was selected, the digital code is entered. These numbers are listed in Table 3-5.
Tx Disable	Yes, No	Programs if the group is receive-only (Section 2.12.3).
Send Turnoff	Yes, No	Programming "Yes" causes the Call Guard squelch turn-off code to be transmitted when the PTT switch is released (Section 2.12.5).
Talk-Around	Yes, No	"Yes" programs the group for talk-around so that transmitting occurs on the receive frequency (Section 2.12.4).
Call (Indicator)	Yes, No	Selects if the call indicator is enabled when a call is received on the group (Section 2.4.2).
Horn	Not applicable	This feature is not available with this transceiver, so it can be left in the default condition.

Table 3-5 Call Guard Codes and Tones

Recommended Tone Call Guard Codes									
Code	Freq	Code	Freq	Code	Freq	Code	Freq	Code	Freq
00	00.0	09	91.5	18	123.0	27	167.9	36*	233.6
01	67.0	10	94.8	19	127.3	28	173.8	37*	241.8
02	71.9	11**	97.4	20	131.8	29	179.9	38*	250.3
03	74.4	12	100.0	21	136.5	30	186.2	39**	69.3
04	77.0	13	103.5	22	141.3	31	192.8	40**	206.5
05	79.7	14	107.2	23	146.2	32	203.5	41* **	229.1
06	82.5	15	110.9	24	151.4	33	210.7	42* **	254.1
07	85.4	16	114.8	25	156.7	34*	218.1		
08	88.5	17	118.8	26	162.2	35*	225.7		
* These tones normally are not used because of their close proximity to the voice frequencies.									
** This tone is normally not used because it may cause interference with adjacent tones.									
Recommended Digital Call Guard Codes									
023	065	131	172	261	346	431	532	654	743
025	071	132	174	263	351	432	546	662	754
026	072	134	205	265	364	445	565	664	
031	073	143	223	271	365	464	606	703	
032	074	152	226	306	371	465	612	712	
043	114	155	243	311	411	466	624	723	
047	115	156	244	315	412	503	627	731	
051	116	162	245	331	413	506	631	732	
054	125	165	251	343	423	516	632	734	

800 MHz Channels

Prog Chan. No.	FCC Chan. No.	Mobile Rx Freq.	Mobile Tx Freq	Prog Chan. No.	FCC Chan. No.	Mobile Rx Freq.	Mobile Tx Freq
1	1	851.0125	806.0125	53	53	852.3125	807.3125
2	2	851.0375	806.0375	54	54	852.3375	807.3375
3	3	851.0625	806.0625	55	55	852.3625	807.3625
4	4	851.0875	806.0875	56	56	852.3875	807.3875
5	5	851.1125	806.1125	57	57	852.4125	807.4125
6	6	851.1375	806.1375	58	58	852.4375	807.4375
7	7	851.1625	806.1625	59	59	852.4625	807.4625
8	8	851.1875	806.1875	60	60	852.4875	807.4875
9	9	851.2125	806.2125	61	61	852.5125	807.5125
10	10	851.2375	806.2375	62	62	852.5375	807.5375
11	11	851.2625	806.2625	63	63	852.5625	807.5625
12	12	851.2875	806.2875	64	64	852.5875	807.5875
13	13	851.3125	806.3125	65	65	852.6125	807.6125
14	14	851.3375	806.3375	66	66	852.6375	807.6375
15	15	851.3625	806.3625	67	67	852.6625	807.6625
16	16	851.3875	806.3875	68	68	852.6875	807.6875
17	17	851.4125	806.4125	69	69	852.7125	807.7125
18	18	851.4375	806.4375	70	70	852.7375	807.7375
19	19	851.4625	806.4625	71	71	852.7625	807.7625
20	20	851.4875	806.4875	72	72	852.7875	807.7875
21	21	851.5125	806.5125	73	73	852.8125	807.8125
22	22	851.5375	806.5375	74	74	852.8375	807.8375
23	23	851.5625	806.5625	75	75	852.8625	807.8625
24	24	851.5875	806.5875	76	76	852.8875	807.8875
25	25	851.6125	806.6125	77	77	852.9125	807.9125
26	26	851.6375	806.6375	78	78	852.9375	807.9375
27	27	851.6625	806.6625	79	79	852.9625	807.9625
28	28	851.6875	806.6875	80	80	852.9875	807.9875
29	29	851.7125	806.7125	81	81	853.0125	808.0125
30	30	851.7375	806.7375	82	82	853.0375	808.0375
31	31	851.7625	806.7625	83	83	853.0625	808.0625
32	32	851.7875	806.7875	84	84	853.0875	808.0875
33	33	851.8125	806.8125	85	85	853.1125	808.1125
34	34	851.8375	806.8375	86	86	853.1375	808.1375
35	35	851.8625	806.8625	87	87	853.1625	808.1625
36	36	851.8875	806.8875	88	88	853.1875	808.1875
37	37	851.9125	806.9125	89	89	853.2125	808.2125
38	38	851.9375	806.9375	90	90	853.2375	808.2375
39	39	851.9625	806.9625	91	91	853.2625	808.2625
40	40	851.9875	806.9875	92	92	853.2875	808.2875
41	41	852.0125	807.0125	93	93	853.3125	808.3125
42	42	852.0375	807.0375	94	94	853.3375	808.3375
43	43	852.0625	807.0625	95	95	853.3625	808.3625
44	44	852.0875	807.0875	96	96	853.3875	808.3875
45	45	852.1125	807.1125	97	97	853.4125	808.4125
46	46	852.1375	807.1375	98	98	853.4375	808.4375
47	47	852.1625	807.1625	99	99	853.4625	808.4625
48	48	852.1875	807.1875	100	100	853.4875	808.4875
49	49	852.2125	807.2125	101	101	853.5125	808.5125
50	50	852.2375	807.2375	102	102	853.5375	808.5375
51	51	852.2625	807.2625	103	103	853.5625	808.5625
52	52	852.2875	807.2875	104	104	853.5875	808.5875

800 MHz Channels

Prog Chan. No.	FCC Chan. No.	Mobile Rx Freq.	Mobile Tx Freq	Prog Chan. No.	FCC Chan. No.	Mobile Rx Freq.	Mobile Tx Freq
105	105	853.6125	808.6125	157	157	854.9125	809.9125
106	106	853.6375	808.6375	158	158	854.9375	809.9375
107	107	853.6625	808.6625	159	159	854.9625	809.9625
108	108	853.6875	808.6875	160	160	854.9875	809.9875
109	109	853.7125	808.7125	161	161	855.0125	810.0125
110	110	853.7375	808.7375	162	162	855.0375	810.0375
111	111	853.7625	808.7625	163	163	855.0625	810.0625
112	112	853.7875	808.7875	164	164	855.0875	810.0875
113	113	853.8125	808.8125	165	165	855.1125	810.1125
114	114	853.8375	808.8375	166	166	855.1375	810.1375
115	115	853.8625	808.8625	167	167	855.1625	810.1625
116	116	853.8875	808.8875	168	168	855.1875	810.1875
117	117	853.9125	808.9125	169	169	855.2125	810.2125
118	118	853.9375	808.9375	170	170	855.2375	810.2375
119	119	853.9625	808.9625	171	171	855.2625	810.2625
120	120	853.9875	808.9875	172	172	855.2875	810.2875
121	121	854.0125	809.0125	173	173	855.3125	810.3125
122	122	854.0375	809.0375	174	174	855.3375	810.3375
123	123	854.0625	809.0625	175	175	855.3625	810.3625
124	124	854.0875	809.0875	176	176	855.3875	810.3875
125	125	854.1125	809.1125	177	177	855.4125	810.4125
126	126	854.1375	809.1375	178	178	855.4375	810.4375
127	127	854.1625	809.1625	179	179	855.4625	810.4625
128	128	854.1875	809.1875	180	180	855.4875	810.4875
129	129	854.2125	809.2125	181	181	855.5125	810.5125
130	130	854.2375	809.2375	182	182	855.5375	810.5375
131	131	854.2625	809.2625	183	183	855.5625	810.5625
132	132	854.2875	809.2875	184	184	855.5875	810.5875
133	133	854.3125	809.3125	185	185	855.6125	810.6125
134	134	854.3375	809.3375	186	186	855.6375	810.6375
135	135	854.3625	809.3625	187	187	855.6625	810.6625
136	136	854.3875	809.3875	188	188	855.6875	810.6875
137	137	854.4125	809.4125	189	189	855.7125	810.7125
138	138	854.4375	809.4375	190	190	855.7375	810.7375
139	139	854.4625	809.4625	191	191	855.7625	810.7625
140	140	854.4875	809.4875	192	192	855.7875	810.7875
141	141	854.5125	809.5125	193	193	855.8125	810.8125
142	142	854.5375	809.5375	194	194	855.8375	810.8375
143	143	854.5625	809.5625	195	195	855.8625	810.8625
144	144	854.5875	809.5875	196	196	855.8875	810.8875
145	145	854.6125	809.6125	197	197	855.9125	810.9125
146	146	854.6375	809.6375	198	198	855.9375	810.9375
147	147	854.6625	809.6625	199	199	855.9625	810.9625
148	148	854.6875	809.6875	200	200	855.9875	810.9875
149	149	854.7125	809.7125	201	201	856.0125	811.0125
150	150	854.7375	809.7375	202	202	856.0375	811.0375
151	151	854.7625	809.7625	203	203	856.0625	811.0625
152	152	854.7875	809.7875	204	204	856.0875	811.0875
153	153	854.8125	809.8125	205	205	856.1125	811.1125
154	154	854.8375	809.8375	206	206	856.1375	811.1375
155	155	854.8625	809.8625	207	207	856.1625	811.1625
156	156	854.8875	809.8875	208	208	856.1875	811.1875

800 MHz Channels

Prog Chan. No.	FCC Chan. No.	Mobile Rx Freq.	Mobile Tx Freq	Prog Chan. No.	FCC Chan. No.	Mobile Rx Freq.	Mobile Tx Freq
209	209	856.2125	811.2125	261	261	857.5125	812.5125
210	210	856.2375	811.2375	262	262	857.5375	812.5375
211	211	856.2625	811.2625	263	263	857.5625	812.5625
212	212	856.2875	811.2875	264	264	857.5875	812.5875
213	213	856.3125	811.3125	265	265	857.6125	812.6125
214	214	856.3375	811.3375	266	266	857.6375	812.6375
215	215	856.3625	811.3625	267	267	857.6625	812.6625
216	216	856.3875	811.3875	268	268	857.6875	812.6875
217	217	856.4125	811.4125	269	269	857.7125	812.7125
218	218	856.4375	811.4375	270	270	857.7375	812.7375
219	219	856.4625	811.4625	271	271	857.7625	812.7625
220	220	856.4875	811.4875	272	272	857.7875	812.7875
221	221	856.5125	811.5125	273	273	857.8125	812.8125
222	222	856.5375	811.5375	274	274	857.8375	812.8375
223	223	856.5625	811.5625	275	275	857.8625	812.8625
224	224	856.5875	811.5875	276	276	857.8875	812.8875
225	225	856.6125	811.6125	277	277	857.9125	812.9125
226	226	856.6375	811.6375	278	278	857.9375	812.9375
227	227	856.6625	811.6625	279	279	857.9625	812.9625
228	228	856.6875	811.6875	280	280	857.9875	812.9875
229	229	856.7125	811.7125	281	281	858.0125	813.0125
230	230	856.7375	811.7375	282	282	858.0375	813.0375
231	231	856.7625	811.7625	283	283	858.0625	813.0625
232	232	856.7875	811.7875	284	284	858.0875	813.0875
233	233	856.8125	811.8125	285	285	858.1125	813.1125
234	234	856.8375	811.8375	286	286	858.1375	813.1375
235	235	856.8625	811.8625	287	287	858.1625	813.1625
236	236	856.8875	811.8875	288	288	858.1875	813.1875
237	237	856.9125	811.9125	289	289	858.2125	813.2125
238	238	856.9375	811.9375	290	290	858.2375	813.2375
239	239	856.9625	811.9625	291	291	858.2625	813.2625
240	240	856.9875	811.9875	292	292	858.2875	813.2875
241	241	857.0125	812.0125	293	293	858.3125	813.3125
242	242	857.0375	812.0375	294	294	858.3375	813.3375
243	243	857.0625	812.0625	295	295	858.3625	813.3625
244	244	857.0875	812.0875	296	296	858.3875	813.3875
245	245	857.1125	812.1125	297	297	858.4125	813.4125
246	246	857.1375	812.1375	298	298	858.4375	813.4375
247	247	857.1625	812.1625	299	299	858.4625	813.4625
248	248	857.1875	812.1875	300	300	858.4875	813.4875
249	249	857.2125	812.2125	301	301	858.5125	813.5125
250	250	857.2375	812.2375	302	302	858.5375	813.5375
251	251	857.2625	812.2625	303	303	858.5625	813.5625
252	252	857.2875	812.2875	304	304	858.5875	813.5875
253	253	857.3125	812.3125	305	305	858.6125	813.6125
254	254	857.3375	812.3375	306	306	858.6375	813.6375
255	255	857.3625	812.3625	307	307	858.6625	813.6625
256	256	857.3875	812.3875	308	308	858.6875	813.6875
257	257	857.4125	812.4125	309	309	858.7125	813.7125
258	258	857.4375	812.4375	310	310	858.7375	813.7375
259	259	857.4625	812.4625	311	311	858.7625	813.7625
260	260	857.4875	812.4875	312	312	858.7875	813.7875

800 MHz Channels

Prog Chan. No.	FCC Chan. No.	Mobile Rx Freq.	Mobile Tx Freq	Prog Chan. No.	FCC Chan. No.	Mobile Rx Freq.	Mobile Tx Freq
313	313	858.8125	813.8125	365	365	860.1125	815.1125
314	314	858.8375	813.8375	366	366	860.1375	815.1375
315	315	858.8625	813.8625	367	367	860.1625	815.1625
316	316	858.8875	813.8875	368	368	860.1875	815.1875
317	317	858.9125	813.9125	369	369	860.2125	815.2125
318	318	858.9375	813.9375	370	370	860.2375	815.2375
319	319	858.9625	813.9625	371	371	860.2625	815.2625
320	320	858.9875	813.9875	372	372	860.2875	815.2875
321	321	859.0125	814.0125	373	373	860.3125	815.3125
322	322	859.0375	814.0375	374	374	860.3375	815.3375
323	323	859.0625	814.0625	375	375	860.3625	815.3625
324	324	859.0875	814.0875	376	376	860.3875	815.3875
325	325	859.1125	814.1125	377	377	860.4125	815.4125
326	326	859.1375	814.1375	378	378	860.4375	815.4375
327	327	859.1625	814.1625	379	379	860.4625	815.4625
328	328	859.1875	814.1875	380	380	860.4875	815.4875
329	329	859.2125	814.2125	381	381	860.5125	815.5125
330	330	859.2375	814.2375	382	382	860.5375	815.5375
331	331	859.2625	814.2625	383	383	860.5625	815.5625
332	332	859.2875	814.2875	384	384	860.5875	815.5875
333	333	859.3125	814.3125	385	385	860.6125	815.6125
334	334	859.3375	814.3375	386	386	860.6375	815.6375
335	335	859.3625	814.3625	387	387	860.6625	815.6625
336	336	859.3875	814.3875	388	388	860.6875	815.6875
337	337	859.4125	814.4125	389	389	860.7125	815.7125
338	338	859.4375	814.4375	390	390	860.7375	815.7375
339	339	859.4625	814.4625	391	391	860.7625	815.7625
340	340	859.4875	814.4875	392	392	860.7875	815.7875
341	341	859.5125	814.5125	393	393	860.8125	815.8125
342	342	859.5375	814.5375	394	394	860.8375	815.8375
343	343	859.5625	814.5625	395	395	860.8625	815.8625
344	344	859.5875	814.5875	396	396	860.8875	815.8875
345	345	859.6125	814.6125	397	397	860.9125	815.9125
346	346	859.6375	814.6375	398	398	860.9375	815.9375
347	347	859.6625	814.6625	399	399	860.9625	815.9625
348	348	859.6875	814.6875	400	400	860.9875	815.9875
349	349	859.7125	814.7125	401	401	861.0125	816.0125
350	350	859.7375	814.7375	402	402	861.0375	816.0375
351	351	859.7625	814.7625	403	403	861.0625	816.0625
352	352	859.7875	814.7875	404	404	861.0875	816.0875
353	353	859.8125	814.8125	405	405	861.1125	816.1125
354	354	859.8375	814.8375	406	406	861.1375	816.1375
355	355	859.8625	814.8625	407	407	861.1625	816.1625
356	356	859.8875	814.8875	408	408	861.1875	816.1875
357	357	859.9125	814.9125	409	409	861.2125	816.2125
358	358	859.9375	814.9375	410	410	861.2375	816.2375
359	359	859.9625	814.9625	411	411	861.2625	816.2625
360	360	859.9875	814.9875	412	412	861.2875	816.2875
361	361	860.0125	815.0125	413	413	861.3125	816.3125
362	362	860.0375	815.0375	414	414	861.3375	816.3375
363	363	860.0625	815.0625	415	415	861.3625	816.3625
364	364	860.0875	815.0875	416	416	861.3875	816.3875

800 MHz Channels

Prog Chan. No.	FCC Chan. No.	Mobile Rx Freq.	Mobile Tx Freq	Prog Chan. No.	FCC Chan. No.	Mobile Rx Freq.	Mobile Tx Freq
417	417	861.4125	816.4125	470	470	862.7375	817.7375
418	418	861.4375	816.4375	471	471	862.7625	817.7625
419	419	861.4625	816.4625	472	472	862.7875	817.7875
420	420	861.4875	816.4875	473	473	862.8125	817.8125
421	421	861.5125	816.5125	474	474	862.8375	817.8375
422	422	861.5375	816.5375	475	475	862.8625	817.8625
423	423	861.5625	816.5625	476	476	862.8875	817.8875
424	424	861.5875	816.5875	477	477	862.9125	817.9125
425	425	861.6125	816.6125	478	478	862.9375	817.9375
426	426	861.6375	816.6375	479	479	862.9625	817.9625
427	427	861.6625	816.6625	480	480	862.9875	817.9875
428	428	861.6875	816.6875	481	481	863.0125	818.0125
429	429	861.7125	816.7125	482	482	863.0375	818.0375
430	430	861.7375	816.7375	483	483	863.0625	818.0625
431	431	861.7625	816.7625	484	484	863.0875	818.0875
432	432	861.7875	816.7875	485	485	863.1125	818.1125
433	433	861.8125	816.8125	486	486	863.1375	818.1375
434	434	861.8375	816.8375	487	487	863.1625	818.1625
435	435	861.8625	816.8625	488	488	863.1875	818.1875
436	436	861.8875	816.8875	489	489	863.2125	818.2125
437	437	861.9125	816.9125	490	490	863.2375	818.2375
438	438	861.9375	816.9375	491	491	863.2625	818.2625
439	439	861.9625	816.9625	492	492	863.2875	818.2875
440	440	861.9875	816.9875	493	493	863.3125	818.3125
441	441	862.0125	817.0125	494	494	863.3375	818.3375
442	442	862.0375	817.0375	495	495	863.3625	818.3625
443	443	862.0625	817.0625	496	496	863.3875	818.3875
444	444	862.0875	817.0875	497	497	863.4125	818.4125
445	445	862.1125	817.1125	498	498	863.4375	818.4375
446	446	862.1375	817.1375	499	499	863.4625	818.4625
447	447	862.1625	817.1625	500	500	863.4875	818.4875
448	448	862.1875	817.1875	501	501	863.5125	818.5125
449	449	862.2125	817.2125	502	502	863.5375	818.5375
450	450	862.2375	817.2375	503	503	863.5625	818.5625
451	451	862.2625	817.2625	504	504	863.5875	818.5875
452	452	862.2875	817.2875	505	505	863.6125	818.6125
453	453	862.3125	817.3125	506	506	863.6375	818.6375
454	454	862.3375	817.3375	507	507	863.6625	818.6625
455	455	862.3625	817.3625	508	508	863.6875	818.6875
456	456	862.3875	817.3875	509	509	863.7125	818.7125
457	457	862.4125	817.4125	510	510	863.7375	818.7375
458	458	862.4375	817.4375	511	511	863.7625	818.7625
459	459	862.4625	817.4625	512	512	863.7875	818.7875
460	460	862.4875	817.4875	513	513	863.8125	818.8125
461	461	862.5125	817.5125	514	514	863.8375	818.8375
462	462	862.5375	817.5375	515	515	863.8625	818.8625
463	463	862.5625	817.5625	516	516	863.8875	818.8875
464	464	862.5875	817.5875	517	517	863.9125	818.9125
465	465	862.6125	817.6125	518	518	863.9375	818.9375
466	466	862.6375	817.6375	519	519	863.9625	818.9625
467	467	862.6625	817.6625	520	520	863.9875	818.9875
468	468	862.6875	817.6875	521	521	864.0125	819.0125
469	469	862.7125	817.7125	522	522	864.0375	819.0375

800 MHz Channels

Prog Chan. No.	FCC Chan. No.	Mobile Rx Freq.	Mobile Tx Freq	Prog Chan. No. [1]	FCC Chan. No. [1]	Mobile Rx Freq.	Mobile Tx Freq
523	523	864.0625	819.0625	576	576	865.3875	820.3875
524	524	864.0875	819.0875	577	577	865.4125	820.4125
525	525	864.1125	819.1125	578	578	865.4375	820.4375
526	526	864.1375	819.1375	579	579	865.4625	820.4625
527	527	864.1625	819.1625	580	580	865.4875	820.4875
528	528	864.1875	819.1875	581	581	865.5125	820.5125
529	529	864.2125	819.2125	582	582	865.5375	820.5375
530	530	864.2375	819.2375	583	583	865.5625	820.5625
531	531	864.2625	819.2625	584	584	865.5875	820.5875
532	532	864.2875	819.2875	585	585	865.6125	820.6125
533	533	864.3125	819.3125	586	586	865.6375	820.6375
534	534	864.3375	819.3375	587	587	865.6625	820.6625
535	535	864.3625	819.3625	588	588	865.6875	820.6875
536	536	864.3875	819.3875	589	589	865.7125	820.7125
537	537	864.4125	819.4125	590	590	865.7375	820.7375
538	538	864.4375	819.4375	591	591	865.7625	820.7625
539	539	864.4625	819.4625	592	592	865.7875	820.7875
540	540	864.4875	819.4875	593	593	865.8125	820.8125
541	541	864.5125	819.5125	594	594	865.8375	820.8375
542	542	864.5375	819.5375	595	595	865.8625	820.8625
543	543	864.5625	819.5625	596	596	865.8875	820.8875
544	544	864.5875	819.5875	597	597	865.9125	820.9125
545	545	864.6125	819.6125	598	598	865.9375	820.9375
546	546	864.6375	819.6375	599	599	865.9625	820.9625
547	547	864.6625	819.6625	600	600	865.9875	820.9875
548	548	864.6875	819.6875	601	-	866.0000	821.0000
549	549	864.7125	819.7125	602	601	866.0125	821.0125
550	550	864.7375	819.7375	603	-	866.0250	821.0250
551	551	864.7625	819.7625	604	602	866.0375	821.0375
552	552	864.7875	819.7875	605	603	866.0500	821.0500
553	553	864.8125	819.8125	606	604	866.0625	821.0625
554	554	864.8375	819.8375	607	605	866.0750	821.0750
555	555	864.8625	819.8625	608	606	866.0875	821.0875
556	556	864.8875	819.8875	609	607	866.1000	821.1000
557	557	864.9125	819.9125	610	608	866.1125	821.1125
558	558	864.9375	819.9375	611	609	866.1250	821.1250
559	559	864.9625	819.9625	612	610	866.1375	821.1375
560	560	864.9875	819.9875	613	611	866.1500	821.1500
561	561	865.0125	820.0125	614	612	866.1625	821.1625
562	562	865.0375	820.0375	615	613	866.1750	821.1750
563	563	865.0625	820.0625	616	614	866.1875	821.1875
564	564	865.0875	820.0875	617	615	866.2000	821.2000
565	565	865.1125	820.1125	618	616	866.2125	821.2125
566	566	865.1375	820.1375	619	617	866.2250	821.2250
567	567	865.1625	820.1625	620	618	866.2375	821.2375
568	568	865.1875	820.1875	621	619	866.2500	821.2500
569	569	865.2125	820.2125	622	620	866.2625	821.2625
570	570	865.2375	820.2375	623	621	866.2750	821.2750
571	571	865.2625	820.2625	624	622	866.2875	821.2875
572	572	865.2875	820.2875	625	623	866.3000	821.3000
573	573	865.3125	820.3125	626	624	866.3125	821.3125
574	574	865.3375	820.3375	627	625	866.3250	821.3250
575	575	865.3625	820.3625	628	626	866.3375	821.3375

800 MHz Channels

Prog Chan. No. [1]	FCC Chan. No. [1]	Mobile Rx Freq.	Mobile Tx Freq	Prog Chan. No. [1]	FCC Chan. No. [1]	Mobile Rx Freq.	Mobile Tx Freq
629	627	866.3500	821.3500	682	677	867.0125	822.0125
630	628	866.3625	821.3625	683	-	867.0250	822.0250
631	629	866.3750	821.3750	684	678	867.0375	822.0375
632	630	866.3875	821.3875	685	679	867.0500	822.0500
633	631	866.4000	821.4000	686	680	867.0625	822.0625
634	632	866.4125	821.4125	687	681	867.0750	822.0750
635	633	866.4250	821.4250	688	682	867.0875	822.0875
636	634	866.4375	821.4375	689	683	867.1000	822.1000
637	635	866.4500	821.4500	690	684	867.1125	822.1125
638	636	866.4625	821.4625	691	685	867.1250	822.1250
639	637	866.4750	821.4750	692	686	867.1375	822.1375
640	638	866.4875	821.4875	693	687	867.1500	822.1500
641	-	866.5000	821.5000	694	688	867.1625	822.1625
642	639	866.5125	821.5125	695	689	867.1750	822.1750
643	-	866.5250	821.5250	696	690	867.1875	822.1875
644	640	866.5375	821.5375	697	691	867.2000	822.2000
645	641	866.5500	821.5500	698	692	867.2125	822.2125
646	642	866.5625	821.5625	699	693	867.2250	822.2250
647	643	866.5750	821.5750	700	694	867.2375	822.2375
648	644	866.5875	821.5875	701	695	867.2500	822.2500
649	645	866.6000	821.6000	702	696	867.2625	822.2625
650	646	866.6125	821.6125	703	697	867.2750	822.2750
651	647	866.6250	821.6250	704	698	867.2875	822.2875
652	648	866.6375	821.6375	705	699	867.3000	822.3000
653	649	866.6500	821.6500	706	700	867.3125	822.3125
654	650	866.6625	821.6625	707	701	867.3250	822.3250
655	651	866.6750	821.6750	708	702	867.3375	822.3375
656	652	866.6875	821.6875	709	703	867.3500	822.3500
657	653	866.7000	821.7000	710	704	867.3625	822.3625
658	654	866.7125	821.7125	711	705	867.3750	822.3750
659	655	866.7250	821.7250	712	706	867.3875	822.3875
660	656	866.7375	821.7375	713	707	867.4000	822.4000
661	657	866.7500	821.7500	714	708	867.4125	822.4125
662	658	866.7625	821.7625	715	709	867.4250	822.4250
663	659	866.7750	821.7750	716	710	867.4375	822.4375
664	660	866.7875	821.7875	717	711	867.4500	822.4500
665	661	866.8000	821.8000	718	712	867.4625	822.4625
666	662	866.8125	821.8125	719	713	867.4750	822.4750
667	663	866.8250	821.8250	720	714	867.4875	822.4875
668	664	866.8375	821.8375	721	-	867.5000	822.5000
669	665	866.8500	821.8500	722	715	867.5125	822.5125
670	666	866.8625	821.8625	723	-	867.5250	822.5250
671	667	866.8750	821.8750	724	716	867.5375	822.5375
672	668	866.8875	821.8875	725	717	867.5500	822.5500
673	669	866.9000	821.9000	726	718	867.5625	822.5625
674	670	866.9125	821.9125	727	719	867.5750	822.5750
675	671	866.9250	821.9250	728	720	867.5875	822.5875
676	672	866.9375	821.9375	729	721	867.6000	822.6000
677	673	866.9500	821.9500	730	722	867.6125	822.6125
678	674	866.9625	821.9625	731	723	867.6250	822.6250
679	675	866.9750	821.9750	732	724	867.6375	822.6375
680	676	866.9875	821.9875	733	725	867.6500	822.6500
681	-	867.0000	822.0000	734	726	867.6625	822.6625

[1] Use the Programming Channel Number, not the FCC Channel Number

800 MHz Channels

Prog Chan. No. [1]	FCC Chan. No. [1]	Mobile Rx Freq.	Mobile Tx Freq	Prog Chan. No. [1]	FCC Chan. No. [1]	Mobile Rx Freq.	Mobile Tx Freq
735	727	867.6750	822.6750	788	778	868.3375	823.3375
736	728	867.6875	822.6875	789	779	868.3500	823.3500
737	729	867.7000	822.7000	790	780	868.3625	823.3625
738	730	867.7125	822.7125	791	781	868.3750	823.3750
739	731	867.7250	822.7250	792	782	868.3875	823.3875
740	732	867.7375	822.7375	793	783	868.4000	823.4000
741	733	867.7500	822.7500	794	784	868.4125	823.4125
742	734	867.7625	822.7625	795	785	868.4250	823.4250
743	735	867.7750	822.7750	796	786	868.4375	823.4375
744	736	867.7875	822.7875	797	787	868.4500	823.4500
745	737	867.8000	822.8000	798	788	868.4625	823.4625
746	738	867.8125	822.8125	799	789	868.4750	823.4750
747	739	867.8250	822.8250	800	790	868.4875	823.4875
748	740	867.8375	822.8375	801	791	868.5000	823.5000
749	741	867.8500	822.8500	802	792	868.5125	823.5125
750	742	867.8625	822.8625	803	793	868.5250	823.5250
751	743	867.8750	822.8750	804	794	868.5375	823.5375
752	744	867.8875	822.8875	805	795	868.5500	823.5500
753	745	867.9000	822.9000	806	796	868.5625	823.5625
754	746	867.9125	822.9125	807	797	868.5750	823.5750
755	747	867.9250	822.9250	808	798	868.5875	823.5875
756	748	867.9375	822.9375	809	799	868.6000	823.6000
757	749	867.9500	822.9500	810	800	868.6125	823.6125
758	750	867.9625	822.9625	811	801	868.6250	823.6250
759	751	867.9750	822.9750	812	802	868.6375	823.6375
760	752	867.9875	822.9875	813	803	868.6500	823.6500
761	-	868.0000	823.0000	814	804	868.6625	823.6625
762	753	868.0125	823.0125	815	805	868.6750	823.6750
763	-	868.0250	823.0250	816	806	868.6875	823.6875
764	754	868.0375	823.0375	817	807	868.7000	823.7000
765	755	868.0500	823.0500	818	808	868.7125	823.7125
766	756	868.0625	823.0625	819	809	868.7250	823.7250
767	757	868.0750	823.0750	820	810	868.7375	823.7375
768	758	868.0875	823.0875	821	811	868.7500	823.7500
769	759	868.1000	823.1000	822	812	868.7625	823.7625
770	760	868.1125	823.1125	823	813	868.7750	823.7750
771	761	868.1250	823.1250	824	814	868.7875	823.7875
772	762	868.1375	823.1375	825	815	868.8000	823.8000
773	763	868.1500	823.1500	826	816	868.8125	823.8125
774	764	868.1625	823.1625	827	817	868.8250	823.8250
775	765	868.1750	823.1750	828	818	868.8375	823.8375
776	766	868.1875	823.1875	829	819	868.8500	823.8500
777	767	868.2000	823.2000	830	820	868.8625	823.8625
778	768	868.2125	823.2125	831	821	868.8750	823.8750
779	769	868.2250	823.2250	832	822	868.8875	823.8875
780	770	868.2375	823.2375	833	823	868.9000	823.9000
781	771	868.2500	823.2500	834	824	868.9125	823.9125
782	772	868.2625	823.2625	835	825	868.9250	823.9250
783	773	868.2750	823.2750	836	826	868.9375	823.9375
784	774	868.2875	823.2875	837	827	868.9500	823.9500
785	775	868.3000	823.3000	838	828	868.9625	823.9625
786	776	868.3125	823.3125	839	829	868.9750	823.9750
787	777	868.3250	823.3250	840	830	868.9875	823.9875

900 MHz Channels

Prog Chan. No.	FCC Chan. No.	Mobile Rx Freq.	Mobile Tx Freq.	Prog Chan. No.	FCC Chan. No.	Mobile Rx Freq.	Mobile Tx Freq.
1	1	935.0125	896.0125	52	52	935.6500	896.6500
2	2	935.0250	896.0250	53	53	935.6625	896.6625
3	3	935.0375	896.0375	54	54	935.6750	896.6750
4	4	935.0500	896.0500	55	55	935.6875	896.6875
5	5	935.0625	896.0625	56	56	935.7000	896.7000
6	6	935.0750	896.0750	57	57	935.7125	896.7125
7	7	935.0875	896.0875	58	58	935.7250	896.7250
8	8	935.1000	896.1000	59	59	935.7375	896.7375
9	9	935.1125	896.1125	60	60	935.7500	896.7500
10	10	935.1250	896.1250	61	61	935.7625	896.7625
11	11	935.1375	896.1375	62	62	935.7750	896.7750
12	12	935.1500	896.1500	63	63	935.7875	896.7875
13	13	935.1625	896.1625	64	64	935.8000	896.8000
14	14	935.1750	896.1750	65	65	935.8125	896.8125
15	15	935.1875	896.1875	66	66	935.8250	896.8250
16	16	935.2000	896.2000	67	67	935.8375	896.8375
17	17	935.2125	896.2125	68	68	935.8500	896.8500
18	18	935.2250	896.2250	69	69	935.8625	896.8625
19	19	935.2375	896.2375	70	70	935.8750	896.8750
20	20	935.2500	896.2500	71	71	935.8875	896.8875
21	21	935.2625	896.2625	72	72	935.9000	896.9000
22	22	935.2750	896.2750	73	73	935.9125	896.9125
23	23	935.2875	896.2875	74	74	935.9250	896.9250
24	24	935.3000	896.3000	75	75	935.9375	896.9375
25	25	935.3125	896.3125	76	76	935.9500	896.9500
26	26	935.3250	896.3250	77	77	935.9625	896.9625
27	27	935.3375	896.3375	78	78	935.9750	896.9750
28	28	935.3500	896.3500	79	79	935.9875	896.9875
29	29	935.3625	896.3625	80	80	936.0000	897.0000
30	30	935.3750	896.3750	81	81	936.0125	897.0125
31	31	935.3875	896.3875	82	82	936.0250	897.0250
32	32	935.4000	896.4000	83	83	936.0375	897.0375
33	33	935.4125	896.4125	84	84	936.0500	897.0500
34	34	935.4250	896.4250	85	85	936.0625	897.0625
35	35	935.4375	896.4375	86	86	936.0750	897.0750
36	36	935.4500	896.4500	87	87	936.0875	897.0875
37	37	935.4625	896.4625	88	88	936.1000	897.1000
38	38	935.4750	896.4750	89	89	936.1125	897.1125
39	39	935.4875	896.4875	90	90	936.1250	897.1250
40	40	935.5000	896.5000	91	91	936.1375	897.1375
41	41	935.5125	896.5125	92	92	936.1500	897.1500
42	42	935.5250	896.5250	93	93	936.1625	897.1625
43	43	935.5375	896.5375	94	94	936.1750	897.1750
44	44	935.5500	896.5500	95	95	936.1875	897.1875
45	45	935.5625	896.5625	96	96	936.2000	897.2000
46	46	935.5750	896.5750	97	97	936.2125	897.2125
47	47	935.5875	896.5875	98	98	936.2250	897.2250
48	48	935.6000	896.6000	99	99	936.2375	897.2375
49	49	935.6125	896.6125	100	100	936.2500	897.2500
50	50	935.6250	896.6250	101	101	936.2625	897.2625
51	51	935.6375	896.6375	102	102	936.2750	897.2750

900 MHz Channels

Prog Chan. No.	FCC Chan. No.	Mobile Rx Freq.	Mobile Tx Freq.	Prog Chan. No.	FCC Chan. No.	Mobile Rx Freq.	Mobile Tx Freq.
103	103	936.2875	897.2875	154	154	936.9250	897.9250
104	104	936.3000	897.3000	155	155	936.9375	897.9375
105	105	936.3125	897.3125	156	156	936.9500	897.9500
106	106	936.3250	897.3250	157	157	936.9625	897.9625
107	107	936.3375	897.3375	158	158	936.9750	897.9750
108	108	936.3500	897.3500	159	159	936.9875	897.9875
109	109	936.3625	897.3625	160	160	937.0000	898.0000
110	110	936.3750	897.3750	161	161	937.0125	898.0125
111	111	936.3875	897.3875	162	162	937.0250	898.0250
112	112	936.4000	897.4000	163	163	937.0375	898.0375
113	113	936.4125	897.4125	164	164	937.0500	898.0500
114	114	936.4250	897.4250	165	165	937.0625	898.0625
115	115	936.4375	897.4375	166	166	937.0750	898.0750
116	116	936.4500	897.4500	167	167	937.0875	898.0875
117	117	936.4625	897.4625	168	168	937.1000	898.1000
118	118	936.4750	897.4750	169	169	937.1125	898.1125
119	119	936.4875	897.4875	170	170	937.1250	898.1250
120	120	936.5000	897.5000	171	171	937.1375	898.1375
121	121	936.5125	897.5125	172	172	937.1500	898.1500
122	122	936.5250	897.5250	173	173	937.1625	898.1625
123	123	936.5375	897.5375	174	174	937.1750	898.1750
124	124	936.5500	897.5500	175	175	937.1875	898.1875
125	125	936.5625	897.5625	176	176	937.2000	898.2000
126	126	936.5750	897.5750	177	177	937.2125	898.2125
127	127	936.5875	897.5875	178	178	937.2250	898.2250
128	128	936.6000	897.6000	179	179	937.2375	898.2375
129	129	936.6125	897.6125	180	180	937.2500	898.2500
130	130	936.6250	897.6250	181	181	937.2625	898.2625
131	131	936.6375	897.6375	182	182	937.2750	898.2750
132	132	936.6500	897.6500	183	183	937.2875	898.2875
133	133	936.6625	897.6625	184	184	937.3000	898.3000
134	134	936.6750	897.6750	185	185	937.3125	898.3125
135	135	936.6875	897.6875	186	186	937.3250	898.3250
136	136	936.7000	897.7000	187	187	937.3375	898.3375
137	137	936.7125	897.7125	188	188	937.3500	898.3500
138	138	936.7250	897.7250	189	189	937.3625	898.3625
139	139	936.7375	897.7375	190	190	937.3750	898.3750
140	140	936.7500	897.7500	191	191	937.3875	898.3875
141	141	936.7625	897.7625	192	192	937.4000	898.4000
142	142	936.7750	897.7750	193	193	937.4125	898.4125
143	143	936.7875	897.7875	194	194	937.4250	898.4250
144	144	936.8000	897.8000	195	195	937.4375	898.4375
145	145	936.8125	897.8125	196	196	937.4500	898.4500
146	146	936.8250	897.8250	197	197	937.4625	898.4625
147	147	936.8375	897.8375	198	198	937.4750	898.4750
148	148	936.8500	897.8500	199	199	937.4875	898.4875
149	149	936.8625	897.8625	200	200	937.5000	898.5000
150	150	936.8750	897.8750	201	201	937.5125	898.5125
151	151	936.8875	897.8875	202	202	937.5250	898.5250
152	152	936.9000	897.9000	203	203	937.5375	898.5375
153	153	936.9125	897.9125	204	204	937.5500	898.5500

900 MHz Channels

Prog Chan. No.	FCC Chan. No.	Mobile Rx Freq.	Mobile Tx Freq	Prog Chan. No.	FCC Chan. No.	Mobile Rx Freq.	Mobile Tx Freq
205	205	937.5625	898.5625	256	256	938.2000	899.2000
206	206	937.5750	898.5750	257	257	938.2125	899.2125
207	207	937.5875	898.5875	258	258	938.2250	899.2250
208	208	937.6000	898.6000	259	259	938.2375	899.2375
209	209	937.6125	898.6125	260	260	938.2500	899.2500
210	210	937.6250	898.6250	261	261	938.2625	899.2625
211	211	937.6375	898.6375	262	262	938.2750	899.2750
212	212	937.6500	898.6500	263	263	938.2875	899.2875
213	213	937.6625	898.6625	264	264	938.3000	899.3000
214	214	937.6750	898.6750	265	265	938.3125	899.3125
215	215	937.6875	898.6875	266	266	938.3250	899.3250
216	216	937.7000	898.7000	267	267	938.3375	899.3375
217	217	937.7125	898.7125	268	268	938.3500	899.3500
218	218	937.7250	898.7250	269	269	938.3625	899.3625
219	219	937.7375	898.7375	270	270	938.3750	899.3750
220	220	937.7500	898.7500	271	271	938.3875	899.3875
221	221	937.7625	898.7625	272	272	938.4000	899.4000
222	222	937.7750	898.7750	273	273	938.4125	899.4125
223	223	937.7875	898.7875	274	274	938.4250	899.4250
224	224	937.8000	898.8000	275	275	938.4375	899.4375
225	225	937.8125	898.8125	276	276	938.4500	899.4500
226	226	937.8250	898.8250	277	277	938.4625	899.4625
227	227	937.8375	898.8375	278	278	938.4750	899.4750
228	228	937.8500	898.8500	279	279	938.4875	899.4875
229	229	937.8625	898.8625	280	280	938.5000	899.5000
230	230	937.8750	898.8750	281	281	938.5125	899.5125
231	231	937.8875	898.8875	282	282	938.5250	899.5250
232	232	937.9000	898.9000	283	283	938.5375	899.5375
233	233	937.9125	898.9125	284	284	938.5500	899.5500
234	234	937.9250	898.9250	285	285	938.5625	899.5625
235	235	937.9375	898.9375	286	286	938.5750	899.5750
236	236	937.9500	898.9500	287	287	938.5875	899.5875
237	237	937.9625	898.9625	288	288	938.6000	899.6000
238	238	937.9750	898.9750	289	289	938.6125	899.6125
239	239	937.9875	898.9875	290	290	938.6250	899.6250
240	240	938.0000	899.0000	291	291	938.6375	899.6375
241	241	938.0125	899.0125	292	292	938.6500	899.6500
242	242	938.0250	899.0250	293	293	938.6625	899.6625
243	243	938.0375	899.0375	294	294	938.6750	899.6750
244	244	938.0500	899.0500	295	295	938.6875	899.6875
245	245	938.0625	899.0625	296	296	938.7000	899.7000
246	246	938.0750	899.0750	297	297	938.7125	899.7125
247	247	938.0875	899.0875	298	298	938.7250	899.7250
248	248	938.1000	899.1000	299	299	938.7375	899.7375
249	249	938.1125	899.1125	300	300	938.7500	899.7500
250	250	938.1250	899.1250	301	301	938.7625	899.7625
251	251	938.1375	899.1375	302	302	938.7750	899.7750
252	252	938.1500	899.1500	303	303	938.7875	899.7875
253	253	938.1625	899.1625	304	304	938.8000	899.8000
254	254	938.1750	899.1750	305	305	938.8125	899.8125
255	255	938.1875	899.1875	306	306	938.8250	899.8250

900 MHz Channels

Prog Chan. No.	FCC Chan. No.	Mobile Rx Freq.	Mobile Tx Freq.	Prog Chan. No.	FCC Chan. No.	Mobile Rx Freq.	Mobile Tx Freq.
307	307	938.8375	899.8375	358	358	939.4750	900.4750
308	308	938.8500	899.8500	359	359	939.4875	900.4875
309	309	938.8625	899.8625	360	360	939.5000	900.5000
310	310	938.8750	899.8750	361	361	939.5125	900.5125
311	311	938.8875	899.8875	362	362	939.5250	900.5250
312	312	938.9000	899.9000	363	363	939.5375	900.5375
313	313	938.9125	899.9125	364	364	939.5500	900.5500
314	314	938.9250	899.9250	365	365	939.5625	900.5625
315	315	938.9375	899.9375	366	366	939.5750	900.5750
316	316	938.9500	899.9500	367	367	939.5875	900.5875
317	317	938.9625	899.9625	368	368	939.6000	900.6000
318	318	938.9750	899.9750	369	369	939.6125	900.6125
319	319	938.9875	899.9875	370	370	939.6250	900.6250
320	320	939.0000	900.0000	371	371	939.6375	900.6375
321	321	939.0125	900.0125	372	372	939.6500	900.6500
322	322	939.0250	900.0250	373	373	939.6625	900.6625
323	323	939.0375	900.0375	374	374	939.6750	900.6750
324	324	939.0500	900.0500	375	375	939.6875	900.6875
325	325	939.0625	900.0625	376	376	939.7000	900.7000
326	326	939.0750	900.0750	377	377	939.7125	900.7125
327	327	939.0875	900.0875	378	378	939.7250	900.7250
328	328	939.1000	900.1000	379	379	939.7375	900.7375
329	329	939.1125	900.1125	380	380	939.7500	900.7500
330	330	939.1250	900.1250	381	381	939.7625	900.7625
331	331	939.1375	900.1375	382	382	939.7750	900.7750
332	332	939.1500	900.1500	383	383	939.7875	900.7875
333	333	939.1625	900.1625	384	384	939.8000	900.8000
334	334	939.1750	900.1750	385	385	939.8125	900.8125
335	335	939.1875	900.1875	386	386	939.8250	900.8250
336	336	939.2000	900.2000	387	387	939.8375	900.8375
337	337	939.2125	900.2125	388	388	939.8500	900.8500
338	338	939.2250	900.2250	389	389	939.8625	900.8625
339	339	939.2375	900.2375	390	390	939.8750	900.8750
340	340	939.2500	900.2500	391	391	939.8875	900.8875
341	341	939.2625	900.2625	392	392	939.9000	900.9000
342	342	939.2750	900.2750	393	393	939.9125	900.9125
343	343	939.2875	900.2875	394	394	939.9250	900.9250
344	344	939.3000	900.3000	395	395	939.9375	900.9375
345	345	939.3125	900.3125	396	396	939.9500	900.9500
346	346	939.3250	900.3250	397	397	939.9625	900.9625
347	347	939.3375	900.3375	398	398	939.9750	900.9750
348	348	939.3500	900.3500	399	399	939.9875	900.9875
349	349	939.3625	900.3625	400	400	940.0000	901.0000
350	350	939.3750	900.3750	401	401	940.0125	901.0125
351	351	939.3875	900.3875	402	402	940.0250	901.0250
352	352	939.4000	900.4000	403	403	940.0375	901.0375
353	353	939.4125	900.4125	404	404	940.0500	901.0500
354	354	939.4250	900.4250	405	405	940.0625	901.0625
355	355	939.4375	900.4375	406	406	940.0750	901.0750
356	356	939.4500	900.4500	407	407	940.0875	901.0875
357	357	939.4625	900.4625	408	408	940.1000	901.1000

900 MHz Channels

Prog Chan. No.	FCC Chan. No.	Mobile Rx Freq.	Mobile Tx Freq.	Prog Chan. No.	FCC Chan. No.	Mobile Rx Freq.	Mobile Tx Freq.
409	409	940.1125	901.1125	446	446	940.5750	901.5750
410	410	940.1250	901.1250	447	447	940.5875	901.5875
411	411	940.1375	901.1375	448	448	940.6000	901.6000
412	412	940.1500	901.1500	449	449	940.6125	901.6125
413	413	940.1625	901.1625	450	450	940.6250	901.6250
414	414	940.1750	901.1750	451	451	940.6375	901.6375
415	415	940.1875	901.1875	452	452	940.6500	901.6500
416	416	940.2000	901.2000	453	453	940.6625	901.6625
417	417	940.2125	901.2125	454	454	940.6750	901.6750
418	418	940.2250	901.2250	455	455	940.6875	901.6875
419	419	940.2375	901.2375	456	456	940.7000	901.7000
420	420	940.2500	901.2500	457	457	940.7125	901.7125
421	421	940.2625	901.2625	458	458	940.7250	901.7250
422	422	940.2750	901.2750	459	459	940.7375	901.7375
423	423	940.2875	901.2875	460	460	940.7500	901.7500
424	424	940.3000	901.3000	461	461	940.7625	901.7625
425	425	940.3125	901.3125	462	462	940.7750	901.7750
426	426	940.3250	901.3250	463	463	940.7875	901.7875
427	427	940.3375	901.3375	464	464	940.8000	901.8000
428	428	940.3500	901.3500	465	465	940.8125	901.8125
429	429	940.3625	901.3625	466	466	940.8250	901.8250
430	430	940.3750	901.3750	467	467	940.8375	901.8375
431	431	940.3875	901.3875	468	468	940.8500	901.8500
432	432	940.4000	901.4000	469	469	940.8625	901.8625
433	433	940.4125	901.4125	470	470	940.8750	901.8750
434	434	940.4250	901.4250	471	471	940.8875	901.8875
435	435	940.4375	901.4375	472	472	940.9000	901.9000
436	436	940.4500	901.4500	473	473	940.9125	901.9125
437	437	940.4625	901.4625	474	474	940.9250	901.9250
438	438	940.4750	901.4750	475	475	940.9375	901.9375
439	439	940.4875	901.4875	476	476	940.9500	901.9500
440	440	940.5000	901.5000	477	477	940.9625	901.9625
441	441	940.5125	901.5125	478	478	940.9750	901.9750
442	442	940.5250	901.5250	479	479	940.9875	901.9875
443	443	940.5375	901.5375				
444	444	940.5500	901.5500				
445	445	940.5625	901.5625				

This page intentionally left blank.

SECTION 4 LTR-NET OVERVIEW

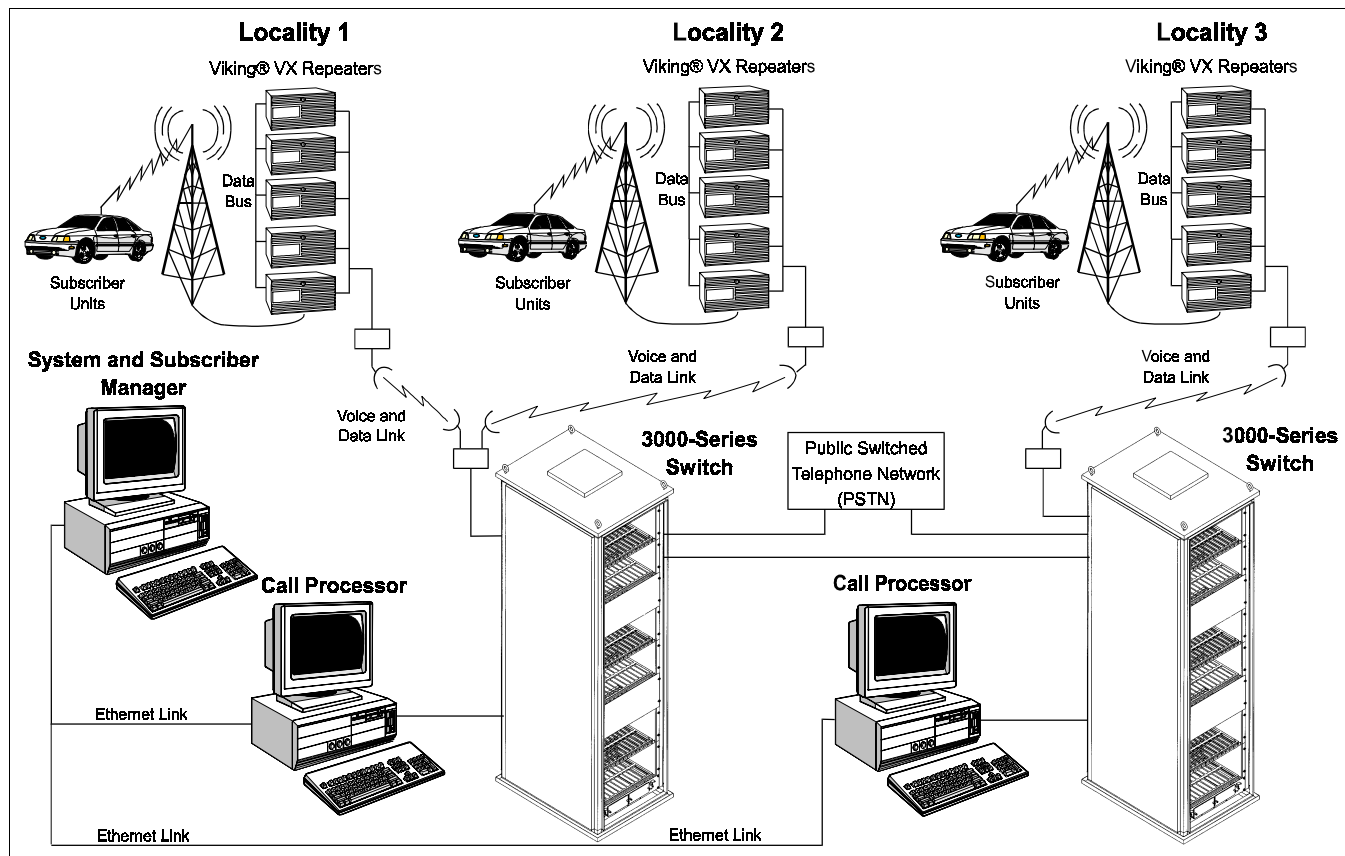

Figure 4-1 LTR-Net™ System

4.1 INTRODUCTION

4.1.1 GENERAL

LTR-Net™ is the next generation of LTR® trunked radio signaling. It provides many new enhanced operating features while maintaining compatibility with most current LTR equipment. Some new LTR-Net features include roaming, unique ID calls, and over-the-air reprogramming. Equipment changes include the addition of an LTR-Net 3000-Series switch and System and Subscriber Manager to provide system control. A diagram of an LTR-Net system is shown in Figure 4-1.

4.1.2 COMPATIBILITY WITH LTR

LTR Subscriber Units Operating in LTR-Net Systems

- Standard group calls occur in the normal manner. These calls can be to other LTR subscriber units or between LTR and LTR-Net subscriber units.
- Wide area group calls can be placed and received (see Section 4.4).
- LTR telephone calls can be placed and received in the normal manner.
- Enhanced LTR-Net features such as roaming and unique ID calls are not available.

- Current LTR subscriber units can remain in service and LTR-Net subscriber units added gradually. This makes upgrading to LTR-Net very convenient and less costly.

LTR-Net Subscriber Units Operating on LTR Systems

- LTR-Net subscriber units can be programmed for LTR operation. Therefore, they can place and receive LTR group and telephone calls in the normal manner.
- Enhanced LTR-Net features such as roaming and unique ID calls are not available to LTR-Net subscriber units operating on LTR systems.

4.1.3 LTR-NET FEATURES

Networking

- Multiple LTR-Net and LTR localities may be linked together to provide wide-area coverage.
- LTR-Net subscriber units can roam between LTR-Net localities and register and de-register automatically when entering and exiting.

Calls from one type of subscriber unit can be patched to another type of subscriber unit at another locality. For example, an LTR-Net subscriber unit could talk to a conventional subscriber unit. Calls can even be cross-band, for example, an UHF conventional subscriber unit could talk to an 800 MHz LTR-Net subscriber unit.

Special Calls

- **Unique ID (UID)** - Calls to be placed to specific subscriber units in the same locality or some other locality.
- **Directed Group** - Calls can be placed to any group in the same locality or some other locality.
- **Telephone** - Calls can be placed over the public switched telephone network (PSTN).
- **Data** - Data can be transmitted to specific location selected by unique ID code (not currently available).

System Control

- When new channels are added to a locality, subscriber units can be updated with those channels over the air. This eliminates the need to bring them back in for reprogramming.
- Over-the-air subscriber unit programming allows the ID codes of up to 128 systems and 128 groups to be changed.
- The system/group currently selected by a subscriber unit can be changed over the air.

A temporary UID keyed to the ESN can be assigned to a subscriber unit when it roams to a new radio system (this feature has not yet been implemented).

- Unauthorized subscriber units can be temporarily or permanently disabled.
- A subscriber unit can be interrogated to determine if it is currently in service. It can also be interrogated for its ESN or unique ID code (see following).

Security

- Each LTR-Net subscriber unit is assigned a unique Electronic Serial Number (ESN), and no two subscriber units in existence should have the same ESN. This number can be interrogated as stated above and is used for such things as assigning a temporary UID.
- Over 65,500 unique ID codes can be assigned in each locality. Each subscriber unit in a locality is usually assigned a different unique ID code although more than one can have the same code if desired.
- Unique ID and group validation (by home repeater/group ID) is performed. If an unauthorized ID is detected, the call is terminated.

Miscellaneous

- Home channel backup is provided by the use of a status channel at each locality. The status channel is used for voice traffic the same as normal channels, but is usually not assigned as a home channel.

- Typical access time for group calls is the same as with LTR operation. Access time for unique ID and auxiliary calls is less than 500 milliseconds.
- Priority access, automatic emergency calls, status messaging, and system security keys are not available.

4.1.4 DEFINITIONS

The following are some terms that are used frequently when describing LTR-Net operation:

Group - A subscriber unit has selectable systems and groups. Each system can have several groups. The group selects the call type and the subscriber unit or units which receive the call. Refer to Section 2.3.6 for more information.

Home Repeater - Each selectable system of LTR and LTR-Net subscriber units has one of the locality repeaters assigned as their “home” repeater. This is the repeater from which “free” and “channel-in-use” information is received (see Section 4.6). In addition, with standard group calls, the home repeater number and a group ID form the “address” of the recipient of a call.

Locality - A group of co-located repeaters typically connected by a common data bus. Refer to Sections 4.2.3 and 2.3.6 for more information.

LTR Signaling - This popular EFJohnson radio trunking system provides the basis for the LTR-Net system. For a complete description of LTR trunking, refer to the LTR Application Note, Part No. 009-0001-002, Revision 8 or later.

Mobile - A transceiver mounted in a vehicle. This term may also be used generically to refer to any transceiver, either mobile or portable, since both operate basically the same. See also “Subscriber Unit”.

Portable - A small handheld transceiver usually battery powered and carried by a person. See also “Subscriber Unit”.

Site - See “Locality”.

Status Repeater - The repeater at a locality designated to provide home channel backup. It transmits call information for all subscriber units on that locality. Refer to Section 4.6 for more information.

System, Radio - This refers to the radio equipment and other infrastructure that is accessed when a call is placed.

System, Selectable - A subscriber unit has selectable systems and groups. Each selectable system consists of one or more groups and is programmed with a unique home repeater (see Section 2.3.6 for more information). A radio system refers to the radio equipment that is accessed when calls are placed.

Subscriber Unit - A generic term referring to both the mobile and portable transceivers being used in the radio system.

Trunked Radio System - A radio system which utilizes multiple radio channels and automatic channel switching to allow all users equal access to any channel not in use. This results in minimum waiting to make a call and maximum utilization of the available radio channels.

Unique ID - A unique number from 1-65503 assigned to each subscriber unit. Although this number is assignable on a per locality basis, the same number is typically assigned on each locality a subscriber unit can access.

4.2 SYSTEM ARCHITECTURE

4.2.1 INTRODUCTION

A diagram of a typical LTR-Net system is shown in Figure 4-1. The number of localities, repeaters per locality, number of 3000-series switches, and other system parameters are determined by the requirements of the particular system. The following is more information on the components shown in Figure 4-1.

4.2.2 SUBSCRIBER UNITS

Subscriber units operating in an LTR-Net locality must be the LTR-Net or LTR type. They may be the mounted in a vehicle (mobiles) and or carried (portables). The features available with each type are as follows:

LTR-Net Subscriber Units

These subscriber units are designed for operation in an LTR-Net radio system and therefore have all LTR-Net features. An optional DTMF keypad is required to place telephone, directed group, and unique ID calls. These subscriber units can also be programmed for LTR and conventional operation, so will operate in those types of radio systems. Standard group and also telephone calls can be placed when operating in an LTR system.

LTR Subscriber Units

These transceivers are designed for operation in LTR and conventional radio systems. They can also be used in an LTR-Net radio system to make standard and wide area group calls and telephone calls. Standard group calls are to mobiles in the same locality, and wide area group calls are to mobiles in some other locality. Enhanced LTR-Net features such as unique ID calls and full roaming capability are not available.

4.2.3 REPEATERS

Viking® VX 2000-series repeaters are used in an LTR-Net system. Models are available for the VHF, UHF, 800 MHz, and 900 MHz frequency bands. One repeater is required for each radio channel.

As with standard LTR repeaters, all the signal processing for the channel is performed by the logic unit in each repeater. This is referred to as distributive processing, and it eliminates the need for a separate controller at each locality.

Audio (voice) and data signals are routed from each repeater to a 3000-series switch. This allows the switch to route the call to other localities and also control certain repeater functions. The link to the switch may be a direct connection if the switch is at the same location or some other type such as microwave, fiber optic, RF, or telephone line. The audio interface to the switch is a standard 600-ohm, four-wire path (transmit and receive pair). The data signal can use an RS-232 interface or it can be FSK tones using the same or a different audio path than the voice.

A “locality” refers to repeaters at the same location that are interconnected by a common high-speed data bus. Up to 20 repeaters can be interconnected, so a locality can include up to 20 repeaters. Although more than 20 repeaters could be co-located, they would be considered separate localities because they are not interconnected by the same data bus. A single data bus can be up to 500 feet long.

Standard LTR and conventional Viking VX and 8000-series repeaters can also be connected to the 3000-Series switch. However, since they would not be using LTR-Net software, the only enhanced LTR-Net feature provided would be wide area group calling (see Section 4.4).

4.2.4 3000-SERIES SWITCH

The 3000-Series Switch connects several different forms of communication together to form a communications network. Each switch is controlled by a Call Processor and System and Subscriber Manager (see next sections). A switch can consist of up to three racks, each containing up to eight shelves. Since each shelf has 12-16 device slots, up to 96-128 slots per rack and up to 288-384 slots per switch are available. Many different modules are available for installation in these slots. The exact number and type required is determined by the requirements of each system.

A single 3000-Series Switch can control up to 30 repeaters. Therefore, if a LTR-Net network consisting of several localities has more than 30 repeaters, one switch is required for every 30 repeaters. A switch can be located at one of the repeater localities or it can be at a separate location. An audio and data link connects the switch to each repeater as described in the preceding section.

When a call is made by a subscriber unit in one locality to a subscriber unit in another locality, the switch provides the necessary patch. Likewise, when a telephone call is placed by a subscriber unit, the switch routes it to the Public Switched Telephone Network (PSTN). Calls can also be routed to a PABX (Private Automatic Branch Exchange). The dial access codes and least cost routing facilities of the PABX can then be utilized.

4.2.5 CALL PROCESSOR

The Call Processor is a Windows NT-based personal computer running switch management software. The Call Processor serves as an interface between the switch and the System and Subscriber Manager (see next section). It contains the database used to process calls on the switch and also logs call information from the switch. The Call Processor performs such tasks as processing wide area calls, subscriber unit registration, and Interrogate and Reassign requests. One Call Processor is required per switch, and it is connected to the switch by two 19,200 baud data links.

4.2.6 SYSTEM AND SUBSCRIBER MANAGER

The System and Subscriber Manager (SSM) is also a Windows NT-based personal computer. It runs the software which provides overall system control. One or more SSMs may be used to control the system. This allows, for example, the system administrator to have overall system control and then permit other operators limited control privileges. Access is by password only, and only functions authorized to a particular user can be accessed. This ensures that only authorized personnel can modify and monitor system resources.

Some SSM functions are as follows:

- Set up and authorize auxiliary and telephone interconnect calls on a unique ID basis. Also authorize group calls on a locality/home/group basis.
- Track the location of individual LTR-Net subscriber units by unique ID.
- Control wide area auxiliary calls by unique ID.
- Track wide area group calls by locality/home/group or unique ID.
- Set up command calls such as Reassign, Interrogate, Mobile Disable, and others.
- Monitor and display information on system activity.
- Record information on individual subscriber unit system usage in a standard database format. This

information can then be exported and used by billing software to generate customer billing.

4.3 STANDARD GROUP CALLS

Standard group calls are between subscriber units at the same locality and use ID codes 1-239 that are assignable on each home repeater. A group ID can be assigned to one subscriber unit or a group of subscriber units as desired. To place a standard group call, all the user does is select the group programmed for the group being called and press the PTT switch. No number is dialed using a DTMF keypad as with special calls described in Section 4.5.

Selectable groups used to make standard group calls are programmed with a group ID code, and the selectable system is programmed with a home repeater number. This home repeater/ID code form the “address” of the group call. Since each selectable system can be programmed with a different home repeater, standard group calls can be placed to any group in a locality.

Standard group calls hold a repeater for only the duration of a transmission, not for the entire call. This provides maximum system efficiency because the time between transmissions can be used by others.

4.4 WIDE AREA GROUP CALLS

The wide area group calling feature allows standard group calls from LTR or LTR-Net subscriber units to be routed to any locality in the LTR-Net system.

Specific locality/home/group ID combinations can be programmed in the SSM (see Section 4.2.6) for wide area calls. Then when a standard group call is detected on one of these combinations, it is automatically routed to the specified localities as well as occurring on the home locality. The home/group can be different on each wide area locality if desired.

Each wide area locality/home/group involved in a wide area call can be programmed as follows:

- The call is always routed to the specified locality, home, and group (if resources are available).

- The call is routed to a specified locality only if a call on the home/group has been recently detected. This results in more efficient use of system resources.
- The call is routed to a specific locality if a tracked unique ID is registered on that locality.

Wide area group calls can also be made over standard LTR and conventional Viking VX repeaters that are connected to a 3000-series LTR-Net switch. However, no other LTR-Net enhanced features are available with those repeaters.

Wide area group calls continue to be received while registration on a new locality occurs. For example, the transceiver can exit a locality while receiving a call, register on a new locality, and then continue receiving the call on the new locality. In addition, a call can be received on the new locality before registration occurs if the call is already active on the new locality.

4.5 SPECIAL CALLS

4.5.1 GENERAL

LTR-Net subscriber units can place Auxiliary, Telephone, and Data special calls. These calls are not available to LTR subscriber units being used on an LTR-Net system. When a special call is placed, a number is dialed which specifies the recipient of the call. The DTMF keypad used to dial this number may be optional, and it is located on the microphone with mobile subscriber units and on the front panel with portable units. Special calls hold the channel until the entire call is complete, not just until the transmission is complete as with group calls. More information on each special call follows.

4.5.2 AUXILIARY CALLS

Auxiliary calls include Unique ID and Directed Group calls. Unique ID calls allow calls to be selectively placed to an individual subscriber unit in any locality. Likewise, Directed Group calls allow standard group calls allow group calls to be selectively placed to any group in any locality. Refer to Section 2.10.1 for more information on these calls.

4.5.3 TELEPHONE CALLS

Telephone calls allow calls to be placed over the public switched telephone network. After the system is accessed, a dial tone sounds and the telephone number being called is entered using the DTMF keypad. Since most subscriber units are half-duplex (do not transmit and receive at the same time), it is not possible for the mobile user to talk and listen at the same time.

If a unique telephone number has been assigned to subscriber unit, it can be called directly from a land-side telephone. If not, the radio system is called and then the unique ID of the mobile must be overdialed similar to when a unique ID call is placed by a subscriber unit.

If a subscriber unit has been assigned a unique telephone number, that number can also be used for unique ID calls. This allows mobile-to-mobile unique ID calls to be made by simply dialing the telephone number of the desired subscriber unit.

4.5.4 DATA CALLS

NOTE: Data calls are not currently available.

Data calls allow data to be transmitted to a specific unique ID. The audio of the receiving equipment is automatically muted as data is received. Data may be transmitted back and forth several times until the entire data exchange is complete because the channel is held for the duration of the call. To transmit a data call, a group programmed for the data special call is selected and then the unique ID is entered, usually automatically by the data equipment. Data calls are received the same as unique ID calls.

4.6 HOME CHANNEL BACKUP

4.6.1 INTRODUCTION

An LTR-Net repeater locality (site) consists of up to twenty interconnected repeaters (see Section 4.2.3). One of these repeaters is usually designated as status repeater and the others are designated as home repeaters (see following). The subscriber units are programmed with the channel numbers of these repeaters. Data signaling can occur continuously with

voice on any repeater because the data occupies the subaudible frequencies below the voice band.

4.6.2 HOME REPEATERS

The home repeater is used by the subscriber unit as its primary source of incoming call and free repeater information. When not receiving or transmitting a call, it is monitoring this repeater. The home repeater is always used to make a call if it is not busy. In addition, if roaming mobiles searching for a new locality cannot locate a suitable status repeater, the home repeater is monitored (see Section 2.10.3). As previously mentioned, up to 239 group ID codes can be assigned on each home repeater, and the home repeater and ID code form the “address” when making group calls.

4.6.3 STATUS REPEATERS

One repeater at each locality is designated the status repeater. The primary function of this repeater is to provide backup for the other locality repeaters that are assigned as home repeaters. It continuously transmits call information for all calls occurring at that locality. The status repeater is used for voice traffic, but is usually not assigned as a home repeater because there would then be no home channel backup on that repeater. Roaming mobiles searching for a new locality monitor the status repeaters (Section 2.10.3). After registration occurs, the home repeater is then monitored.

4.6.4 BACKUP OPERATION

If subscriber units were limited to only their home repeater to receive update information and that repeater became inoperative, all subscriber units that were assigned to that repeater would then be unable to place or receive calls. To prevent this from happening, the status repeater can also be monitored for call information.

If the signal from the home repeater is lost or falls below a minimum threshold, the subscriber unit automatically begins monitoring the locality status repeater. If a usable signal is detected from the status repeater, it continues to monitor that repeater. If a message is detected that has its home repeater as the “channel-in-use” or “free” repeater, the subscriber unit then returns to monitoring its home repeater.

A roaming subscriber unit also monitors the status repeater in this manner when the home repeater signal drops below the threshold level. However, the status repeater signal level will probably also be below the threshold, so the subscriber unit then begins searching for a new locality.

4.6.5 HOME CHANNEL ALIASING

The LTR-Net Home Channel Aliasing feature increases the number of addresses available on a locality for group calls. It does this by allowing calls to be programmed on non-existent home repeaters.

Each home repeater can be programmed with up to 239 group ID codes. Assume a locality has four active repeaters and one of these is the status repeater (which is normally not assigned as a home repeater as described in Section 4.6.3). The number of calls that can be programmed are then as follows:

Without Aliasing - 3 x 239 or 717 calls

With Aliasing - 20 x 239 or 4780 calls

When a call is placed on a non-existent home repeater, the subscriber unit automatically uses the next lower numbered active repeater. Refer to Section 2.10.6 for more information.

NOTE: Since this feature does not increase system capacity, adding too many users may result in unsatisfactory operation due to frequent busy conditions.

4.7 OTHER LTR-NET FEATURES

4.7.1 UNIQUE ID CODES

Each LTR-Net subscriber unit in an LTR-Net system is assigned a unique ID (a different unique ID can be programmed for each locality if desired). Up to 65,503 user ID codes are assignable in each locality, and a few other codes are used for system functions. When an LTR-Net subscriber unit places a special call, it transmits its unique ID code along with other information such as the call type. This data is received by the repeater and passed on to the SSM.

Uses of unique ID codes include registering and de-registering on a locality, unit identification, airtime billing, and unique ID calls (see “Unique ID Calls” in Section 4.5.2). A call can also be made to individual

subscriber units using a group call if the group is assigned to only one subscriber unit.

A temporary unique ID code can also be assigned over-the-air. This may be required to allow a full roaming subscriber unit to access a locality that is not part of its network. Temporary unique ID codes are keyed to the ESN of the subscriber unit (see next section). A roaming subscriber unit may also request a temporary unique ID code. If no response is received from the system after three requests, access was denied and the unit must select another locality.

NOTE: The preceding feature has not yet been implemented.

4.7.2 ELECTRONIC SERIAL NUMBER (ESN)

Each subscriber unit, both mobile and portable, is given an electronic serial number at the factory. No two LTR-Net subscriber units should ever have the same ESN. This is a 32-bit number with the first 7 bits reserved for the manufacturer code and the other 25 for the serial number. This allows for up to 128 manufacturers and over 33.5 million serial numbers per manufacturer. The ESN can be interrogated over the air as described next.

4.7.3 ESN AND UNIQUE ID REQUESTS

The system operator can request the Electronic Serial Number (see preceding section) or unique ID (see Section 4.7.1) that is programmed in a subscriber unit. If the ESN is desired, the unique ID code of the subscriber unit is specified, and vice versa. The subscriber unit then responds with the requested information.

4.7.4 INTERROGATE

A system manager can interrogate any subscriber unit in the field to determine if it is in service. The unit is selected by specifying its unique ID code. If it is in service, it automatically responds with an acknowledgment message, and this will be indicated on the system manager's screen.

4.7.5 KILL AND SLEEP

If a subscriber unit has been lost or stolen or is being used to interfere with communications, it can be

permanently disabled by the kill command or temporarily disabled by the Sleep command. If the Kill command is sent, the unit responds indicating that it has received the message and then it permanently disables itself. It must then be brought back in for reprogramming to make it functional again. If the sleep command is sent instead, the transceiver is disabled until the Interrogate command is sent. Refer to Section 2.10.5 for more information.

4.7.6 OVER-THE-AIR REPROGRAMMING

Any system and group position of a subscriber unit can be reprogrammed over the air. Up to 128 system selections and 128 group selections are allowed. In addition, group alpha tags of up to 16 characters can be reprogrammed if applicable. The subscriber unit to be reprogrammed is selected by specifying its unique ID code. One use of this feature is to allow a subscriber unit to place and receive calls for which it was not originally programmed.

4.7.7 MOVE TO SPECIFIC SYSTEM/GROUP

The system/group currently selected by a subscriber unit can also be dynamically changed over the air. As with reprogramming, the subscriber unit is selected by specifying its unique ID code. When the command is received, the unit automatically changes to the specified system/group. This function may be used, for example, to ensure that the correct system/group is selected to receive an important message.

4.7.8 AUTO-REGISTRATION AND DE-REGISTRATION

LTR-Net subscriber units are programmed with the locality information of all localities they can roam into. This includes the status and home channels and the channel frequencies of the locality repeaters. Roaming must be enabled and an LTR-Net system selected for roaming to occur (it is not necessary to enable scanning).

Normally, a subscriber unit monitors its home channel for incoming call and free channel information. When moving out of range of a locality, the home repeater received signal strength decreases below a certain threshold called Dropout Criteria (see Section 2.10.3). This threshold is determined by the percentage of good data messages received over a

certain period. When the home repeater signal strength drops below the threshold, the status channel of that locality is then monitored (see Section 4.6). If its signal strength is also below the threshold, the subscriber unit then begins searching for another locality.

The subscriber unit then begins checking the status repeater of other programmed localities. If one is located above the Capture Criteria threshold, it will attempt to register on the locality. If no suitable status repeaters could be located, the programmed home repeaters are monitored.

When a new locality is located, the subscriber unit registers on the locality by sending messages indicating its unique ID code and the home channel it will monitor. The system then knows the location of that subscriber unit and will automatically route unique ID calls to the new locality.

When a subscriber unit is no longer in service (power is turned off), a de-registration message is automatically sent if possible. This prevents the system from wasting resources trying to reach out-of-service units. Power is automatically held on until this message is sent.

4.7.9 NEW CHANNEL UPDATES

New subscriber units are initially programmed with the channel numbers of all repeaters at each locality. These are then the channels that can be accessed when placing and receiving calls on that locality. If new channels are later added, the subscriber units can be updated with the new channels over the air. This eliminates the need to bring subscriber units back in for reprogramming. Refer to Section 2.10.4 for more information.

This page intentionally left blank.



Part No. 001-8170-100
4-99hph (First Issue) Printed in U.S.A.